



**AGENDA
BOARD OF ADJUSTMENT
REGULAR MEETING
JUNE 4, 2026
5:00 PM
CITY HALL COMMISSION CHAMBERS
204 ASH STREET
FERNANDINA BEACH, FL 32034**

- 1. CALL TO ORDER / ROLL CALL / DETERMINATION OF QUORUM**
- 2. PLEDGE OF ALLEGIANCE**
- 3. APPROVAL OF MEETING MINUTES**
 - 3.1 Approval of Minutes from the Regular Meeting of May 20, 2026
- 4. OLD BUSINESS**
- 5. NEW BUSINESS**
 - 5.1 **BOA 2026-0002 - ERIC CORBETT, 409 STANLEY DRIVE**
Variance request from LDC Section 1.03.05 Construction or Demolition of Structures on Combined Lots, to subdivide a 100' X 203' lot into two parcels measuring 100' X 100' and 100' X 103'. (*Quasi-Judicial*)
- 6. BOARD BUSINESS**
- 7. STAFF REPORT**
- 8. PUBLIC COMMENT**
- 9. ADJOURNMENT**

NEXT BOA REGULAR MEETING IS SCHEDULED FOR JULY 15, 2026.

All members of the public are invited to be present and be heard. Persons with disabilities requiring accommodations in order to participate in this program or activity should contact (904) 310-3115 or through the Florida Relay Services at 711 at least 24 hours in advance to request such accommodations.

All interested parties may appear at said meeting and be heard as to the advisability of any action, which may be considered with respect to such matter. For information regarding this matter, please contact the Planning Department (904) 310-3135.



**MINUTES
BOARD OF ADJUSTMENT
REGULAR MEETING
MAY 20, 2026
5:00 PM
CITY HALL COMMISSION CHAMBERS
204 ASH STREET
FERNANDINA BEACH, FL 32034**

1. CALL TO ORDER: 5:00 PM

ROLL CALL / DETERMINATION OF QUORUM

Johnny Miller
Barry Hertslet

Len Kreger (Vice-Chair)
Fred Johnson

ABSENT

Steven Papke (Chair)
Frank Miller (Alt 1)

OTHERS PRESENT

Mia Sadler, Planner II
Glenn Akramoff, Deputy City Manager
Teresa Prince, City Attorney
Mackennah Tarmey, Recording Secretary

2. PLEDGE OF ALLEGIANCE

3. APPROVAL OF MEETING MINUTES

3.1 Approval of Minutes from the Regular Meeting of March 18, 2026.

ACTION TAKEN: A motion was made by Member Johnny Miller, seconded by Member Johnson, to approve the Minutes for the Regular Meeting of March 18, 2026, as presented.

Vote upon passage of the motion was taken by voice vote, and being all ayes, carried.

4. OLD BUSINESS

5. NEW BUSINESS

5.1 BOA 2026-0002 - ERIC CORBETT, 409 STANLEY DRIVE

Variance request from LDC Section 1.03.05 Construction or Demolition of Structures on Combined Lots, to subdivide a 100' X 203' lot into two parcels measuring 100' X 100' and 100' X 103'. (*Quasi-Judicial*)

Teresa Prince, City Attorney, explained that there are four (4) members present and that a quorum is made. She then

DRAFT

announced that the hearing tonight would require a unanimous vote in the affirmative from all four (4) members present to approve this case and asked the applicant if he wished to proceed with the hearing or request continuance.

Eric Corbett, 409 Stanley Drive, exercised his rights to ask for a continuance of his hearing for BOA case 2026-0002 to a date certain of June 17th, 2026.

At this time, Member Johnny Miller noted that he would not be available on June 17, 2026. Vice-Chair Kreger stipulated that the continuance will be requested to a date certain of June 17, 2026, and that upon confirmation of attendance from all members, a date will be confirmed in June 2026.

6. BOARD BUSINESS

No board business was discussed.

7. STAFF REPORT

No staff report was presented.

8. PUBLIC COMMENT

9. ADJOURNMENT: 5:04PM

Mackannah Tarmey, Recording Secretary

Len Kreger, Vice-Chair



BOARD OF ADJUSTMENT STAFF REPORT

BOA 2026-0002

May 20, 2026

Agent/Owner:	Eric Corbett
Property Address:	409 Stanley Drive
Parcel Number:	00-00-31-128A-0005-0000
Requested action:	VARIANCE REQUEST from Land Development Code Section: 1.03.05 Construction or Demolition of Structures on Combined Lots, to subdivide a 100' X 203' lot into two parcels measuring 100' X 100' and 100' X 103'.
Current zoning:	R-1
FLUM land use category:	Low Density Residential
Existing uses on the site:	Vacant

All required application materials have been received. All fees have been paid. All required notices have been made.

Aerial View:

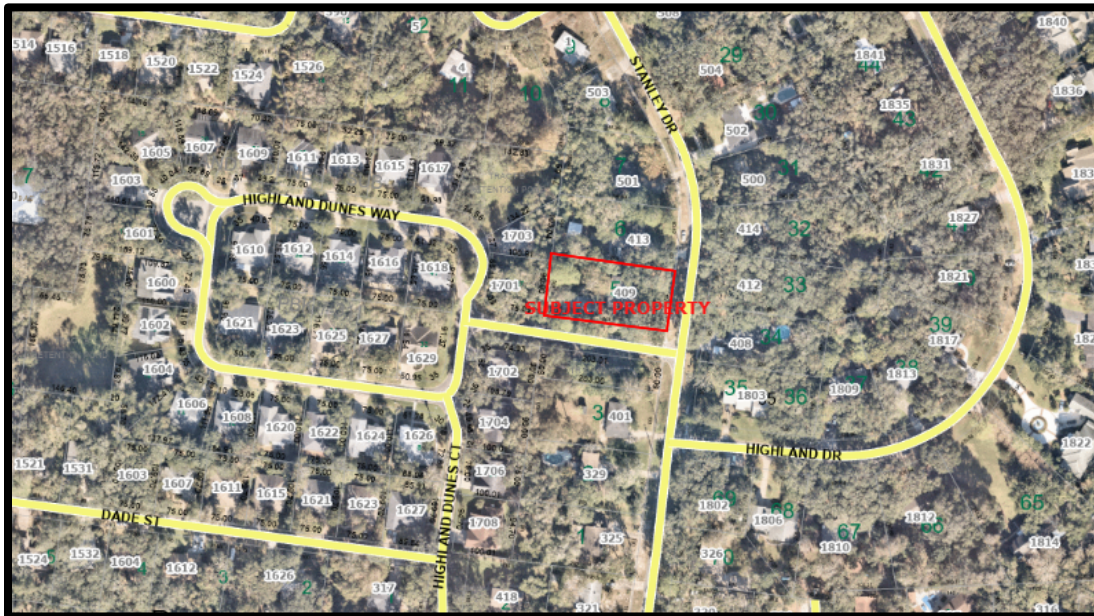

Small scale map:

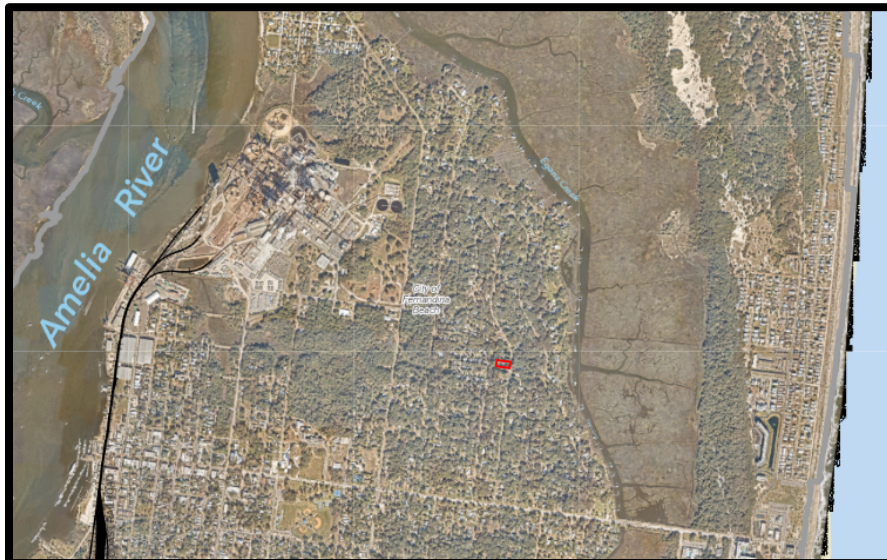

Zoning:



Street View:



Figure 1 View from corner of Stanley Dr and Highland Dunes Way



Figure 2 View looking west down Highland Dunes Way



Figure 3 View looking west at the subject property

SUMMARY OF REQUEST AND BACKGROUND INFORMATION:

The property in question, located at 409 Stanely Drive, is a 0.47-acre lot upon which a house and pole barn was demolished between August-September of 2025 through permits: DEMR-2025-0063 and DEMR-2025-0064. The property is now vacant and the owner, Mr. Eric Corbett, wishes to divide the lot into two lots for the purpose of development of one single family home and the sale of the other lot to a family member. Shortly after the purchase of this property and subsequent demolitions of the structures, Mr. Corbett came into the Planning and Conservation Department to confirm that the division of the lot into two lots, and that the standards of lot size for the R-1 zoning district could be met. He received verbal confirmation from multiple staff members. In October of 2025, after an application for a Lot Line Adjustment was submitted, the Planning Manager and City Attorney made the interpretation that section 1.03.05 of the Land Development Code applied to this scenario. A meeting was held between Mr. Corbett, the City Attorney, and the Planning and Conservation Department to discuss next steps. At the meeting, it was reaffirmed that 1.03.05 applies to the lot as it states: “on property containing **one or more platted lots** or portions thereof (excluding walls or fences), such lots thereafter constitute one building site and must be considered the ‘lot of record’”. Staff advised Mr. Corbett to make an application to the Board of Adjustment for relief from this section of the Land Development Code.

Section 1.03.05 of the Land Development Code reads: “1.03.05 CONSTRUCTION OR DEMOLITION OF STRUCTURES ON COMBINED LOTS

A. In order to maintain open space, visual corridors, neighborhood character, property values and visual attractiveness of residential areas, wherever there may exist a single-family detached residential unit or, a duplex structure or any auxiliary building or structure, including but not limited to, swimming pools, or any other improvement which was heretofore constructed on property containing one or more platted lots or portions thereof (excluding walls or fences), such lots thereafter constitute one building site and must be considered the “lot of record”, and no permit will be issued for the construction of more than one residential dwelling unit on the site. All construction on the building site must comply with all existing zoning and density requirements.

B. The demolition or removal of any residence or structure, whether voluntary or involuntary, does not have the effect of changing the establishment of the building site.

C. A change from the foregoing provisions for the purpose of establishing building sites, or separation of building sites requires supermajority approval by the Board of Adjustment in accordance with the variance approval process contained in Section 10.02.00 in a quasi-judicial hearing at which all interested persons will be afforded an opportunity to be heard.”

The existing lot is 100 ft wide on the boundary with Stanley Dr and 203 ft long along the boundary if Highland Dunes Way. The two potential lots would meet the requirements for the R-1 zoning district. To subdivide the property into two lots, compliant with the lot size requirements laid out in the site design standards in Land Development Code, a variance must be granted by the BOA.

Survey of existing Lot 5:

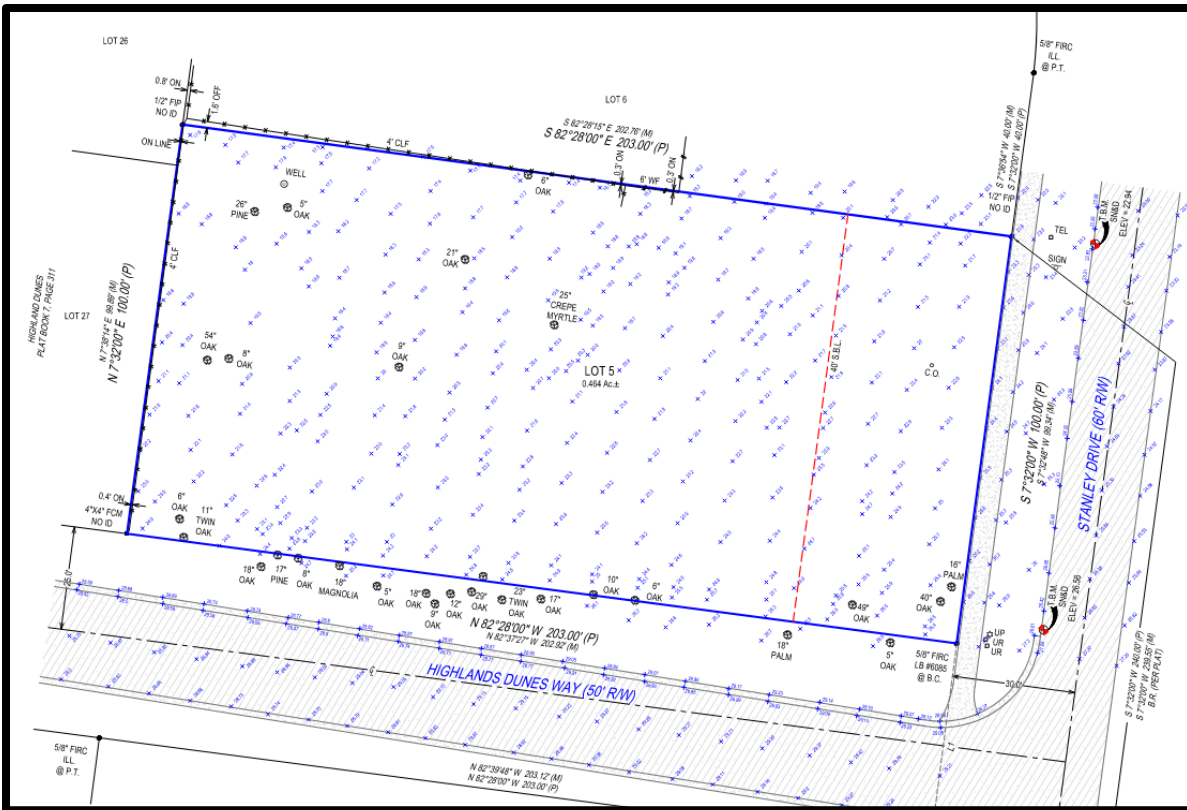

Survey of "Easterly 103' Lot 5":

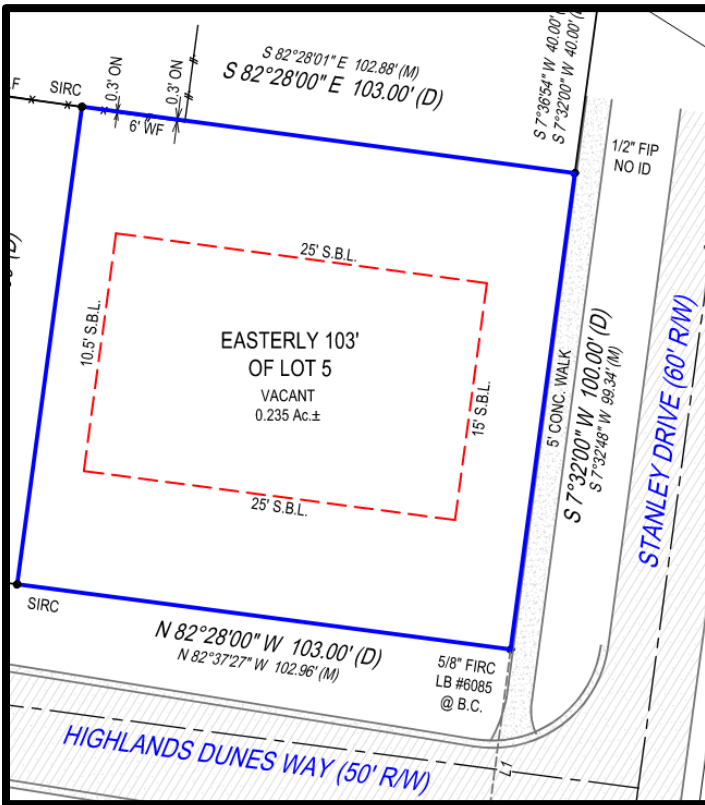

Survey of “Westerly 100’ of Lot 5”:

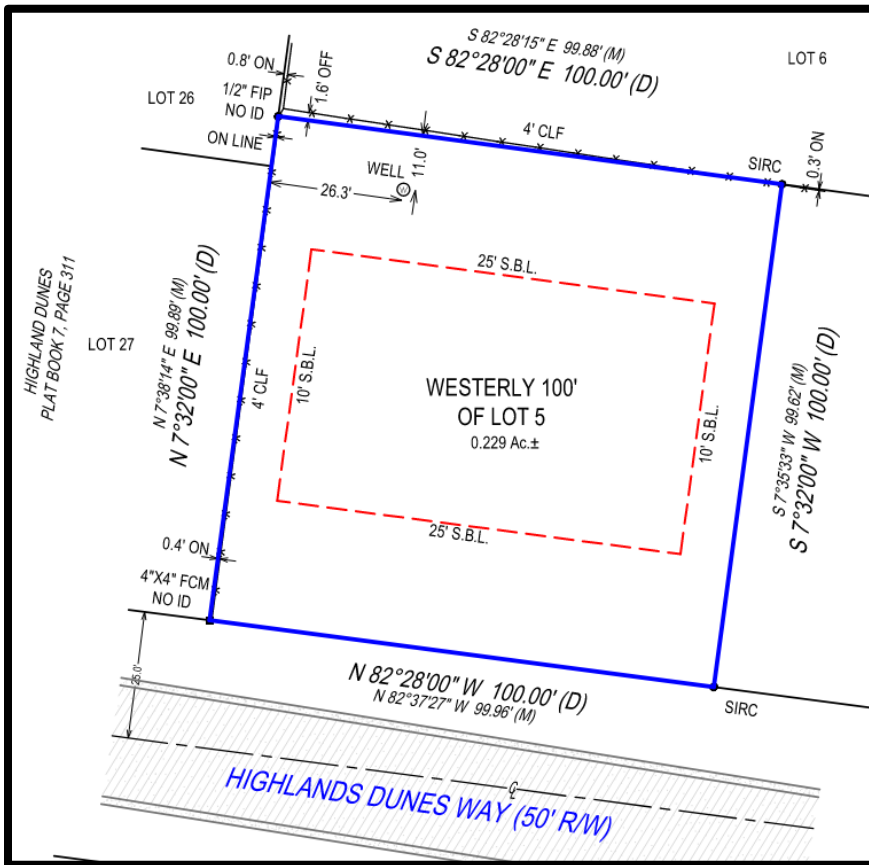

APPLICABLE POLICY GUIDANCE:

CITY OF FERNANDINA BEACH LAND DEVELOPMENT CODE:

Staff’s review of this application finds it is not subject to any of the twelve limitations of Section 10.02.01 and can therefore be considered by the Board of Adjustment. The following analysis of the six criteria for granting a variance is reviewed for compliance with the Land Development Code.

CITY OF FERNANDINA BEACH COMPREHENSIVE PLAN:

The following Comprehensive Plan Goals, Objectives, and Policies are applicable in this case:

- Policy 1.02.05- The City’s land development code shall include the following: (D): Subdivision of land: Land development regulations shall provide for the division of land and the design of plated development projects.
- Policy 1.02.07 - The City shall implement the Fernandina Beach Comprehensive Plan in a manner that acknowledges private property rights.
- Policy 1.02.10 - The City shall protect privacy and access to light, air, and open space. The City shall consider regulations such as building placement on a site, building design, and building orientation as one means to achieve this policy.
- Objective 1.06: COMMUNITY CHARACTER: Community character is reflected in lot sizes, house sizes, site placement, height, architectural features and existing vegetation. The City shall strive to stabilize and preserve neighborhoods and establish urban design standards which protect and promote quality of life, in order to prevent teardowns, encourage re-use, infill and new development.

- Policy 1.06.06. - While providing other housing forms and types at appropriate locations in order to diversify housing choice, the City shall maintain and enhance its existing conventional, single-family neighborhoods as essential and valuable to providing stable housing in the city and in their support of nearby mixed-use, commercial, office and retail activity centers.
- Policy 1.07.04. - Low Density Residential (LDR)
 - a. Areas delineated on the FLUM for low density residential development shall accommodate permanent residential development and shall be comprised of single-family detached homes on individual lots.
 - d. The low-density residential designation is established to:
 1. Protect the quality and character of existing low density single-family neighborhoods.
 2. Preserve open space.
 3. Prevent encroachment by commercial uses, including hotels, motels, bed and breakfast units, resort rentals, or other forms of transient accommodations, and incompatible non-residential uses.
 4. Encourage densities that are compatible with existing and anticipated future developments.
 5. Promote compatibility with natural features of the land; and,
 6. Minimize the burden on existing and projected supportive public services and facilities within the area.
- Goal 9: Pursuant to Section 163.3177(6)(i), Florida Statutes the following rights will be considered in local decision making:
 1. The right of a property owner to physically possess and control his or her interests in the property, including easements, leases, or mineral rights.
 2. The right of a property owner to use, maintain, develop, and improve his or her property for personal use or for the use of any other person, subject to state law and local ordinances

ANALYSIS:

For an application for a variance to be approved or approved with conditions, the BOA shall make a positive finding regarding each of the following provisions:

Consistent with Criteria? All questions must be answered in the affirmative in order for staff to recommend approval of a variance. Negative answers must be addressed in the findings.

Criteria	Applicant Response	Staff Analysis	Meets Criteria
<u>1. Special Conditions</u> <i>Special conditions and circumstances exist which are peculiar to the land, structure, or building involved and which are not applicable to other lands, structures, or buildings in the same zoning district. Special</i>	Shortly after purchasing the property, but prior to our application to demolish the existing home and pole barn, I met with the city planner and discussed my plans to demolish those structures and split the lot into two buildable lots – one for me to build on and the other for my brother to build on – and was given verbal permission to proceed. That verbal permission was then confirmed in an email exchange that followed the in-person meeting at the city	Yes. The property is located on the corner of Stanley Drive and Highland Dunes Way. The property is part of a 1950 plat, Forest Hills, in which most lot sizes were greater than 200 ft in depth, which is uncommon for more recently platted lots. The lot directly to the south, was developed into a road to access a 2007 development, Highland Dunes. The lot sizes within the newer development, with R-1	<input type="checkbox"/> No <input checked="" type="checkbox"/> Yes

<p>conditions or circumstances do not result from actions of the applicant and are not based on a desire to reduce development costs.</p>	<p>hall offices. The lot that is currently 203 feet by 100 feet will be split to create one lot that is 103 feet by 100 feet that will face Stanley Drive (as the previous home did) an additional lot of 100 feet by 100 feet that will face Highland Dunes Way. The special condition is the previous construction and current existence of the roadway “Highland Dunes Way” that was done 202-25 years ago, but long after the creation of the original Forest Hills subdivision plat in the 1950s. This roadway provides the access needed to create two lots where only one existed before.</p>	<p>zoning, are smaller with dimensions widths of 75 by roughly 100.</p>	
<p>2. Special Privilege Granting the variance does not confer upon the applicant a special privilege that is denied by the Land Development Code to other lands, structures, or buildings in the same zoning district.</p>	<p>If there were similar circumstances on a different lot I would think the variance would be provided there as well.</p>	<p>Yes. Any property owner in the City of Fernandina Beach may apply to the Board of Adjustment for a variance as long as the request does not contain any of the limitations of Section 10.02.01. Similar cases in which property owners have requested to divide a lot that previously were developed as a single family home have been directed to the Board of Adjustment.</p>	<p><input type="checkbox"/> No <input checked="" type="checkbox"/> Yes</p>
<p>3. Literal Interpretation Literal interpretation of the provisions of the Land Development Code would deprive the applicant of rights commonly enjoyed by other properties in the same zoning district.</p>	<p>The adjoining Highland Dunes subdivision has a minimum 75-foot lot width.</p> <p>I should note that the Land Development Code 1.03.05 to me seems to be poorly written. The title of the Code reads “Construction or Demolition of Structures on Combined Lots”. It is this code that I was told I am violating and therefore need to request a variance to obtain relief from. At my first reading of the code, I simply thought that the code did not apply to me since I do not own a “combined lot” and the lot exists today the same way it has existed since it was originally platted – LOT 5 FOREST HILLS. But in the body of the code, it references creating a “lot of record” when “one or more lots” have been built on. This phrase “one or more lots” I think was intended to be written as “more than one lot”. If it were written that way it would align perfectly with the title of the code that references “combined lots”. Also the term “one or more lots” is duplicitous</p>	<p>Yes. The literal interpretation of the LDC would deprive the applicant of rights commonly enjoyed by other properties in this zoning district. Owners of residentially zoned properties in the R-1 zoning district are permitted to create lots with 75 feet of width per LDC Table 4.02.01(J). The requested lots have width of 100 and 103 feet with 100 feet of depth each. R-1 density allows for 4 dwelling units per acre. With each lot being 0.229 acres, plus inclusion of the right-of-way, the proposed lots would meet the requirements of the zoning district.</p>	<p><input type="checkbox"/> No <input checked="" type="checkbox"/> Yes</p>

	in that it would include ALL non-zero lot circumstances so if it really meant that, it would be unnecessary to say it at all as it would apply to all circumstances.		
4. Minimum Variance <i>The variance requested is the minimum variance needed that will make possible the reasonable use of the land, structure, or building.</i>	The variance request is to split the single lot into only two lots. The two created lots will be 100 and 103 feet wide respectively and are still much wider than the minimum 75 feet required in R-1 zoning and the lot widths that currently exist throughout the adjoining Highland Dunes subdivision. It should be noted that the two homes are expected to be smaller in footprint than the previous home and pole barn, creating less impervious area and minimal trees to be removed.	Yes. The variance requested is to split the lot into two parcels. The applicant is not requesting a variance from any other element of the LDC. Based on the interpretation of this element of the code, the property owner was required to apply for a variance to fulfill the request.	<input type="checkbox"/> No <input checked="" type="checkbox"/> Yes
5. General Harmony <i>Granting the variance will be in harmony with the general intent and purpose of the Land Development Code and Comprehensive Plan.</i>	Most lots in the previously existing Forest Hills subdivision are 100 feet wide and with varying depths that are up to 200 feet. Lots in the newer Highland Dunes subdivision are 75 feet wide with depths that vary from 75 feet to 110 feet. The two lots created will be approximately 100 feet by 100 feet creating a natural transition between the two subdivisions.	Yes. The splitting of the large lot into two would create lot sizes that are similar to the lot sizes in the Forest Hills plat and the Highland Dunes plat. This would create a gradual transition between the neighborhoods as that road serves as the entrance to the Highland Dunes subdivision. Further, the proposed lot sizes would meet the City's requirements for lot sizes in the R-1 zoning district.	<input type="checkbox"/> No <input checked="" type="checkbox"/> Yes
6. Public Interest <i>Granting the variance is compatible with surrounding properties, will not cause injury to the area involved, or otherwise be detrimental to the public health, safety, welfare or environment.</i>	The proposed lots would be compatible with other properties along Stanley Drive and Highland Dunes Way that contain varying lot widths that are both greater than and lesser than the width of the proposed lots, therefore, the granting of the variance would not cause any injury to the area, or otherwise be detrimental to the public health, safety, welfare or environment. .	Yes. Granting the variance will not infringe on public interest as the former structure and accessory structure had larger footprints than the footprints that would be available on the proposed lot. The Forest Hills plat allows for a variety of setback widths based on lot size. The appropriate setback for the lot size will be applied to the newly created lots, if approved.	<input type="checkbox"/> No <input checked="" type="checkbox"/> Yes

FINAL ANALYSIS AND RECOMMENDATION:

In conclusion, staff recommends approval of the requested variance to allow Lot 5 of the Forest Hills subdivision to be split into two lots that meet the requirements for lot size for lots in the R-1 zoning district.

The variance requested is consistent/inconsistent with the criteria for granting a variance as follows:

	Consistent	Inconsistent
1. Special Conditions	X	
2. Special Privilege	X	
3. Literal Interpretations	X	
4. Minimum Variance	X	
5. General Harmony	X	
6. Public Interest	X	

Staff finds that the requested action, as presented, **DOES meet** the six criteria for granting a variance, therefore staff recommends **APPROVAL**.

STAFF RECOMMENDED MOTION AND FINDINGS FOR BOARD CONSIDERATION:

I move to approve/deny BOA case number 2026-0002;

AND I move that the BOA make the following findings of fact and conclusions of law part of the record:

That BOA case 2026-0002 as presented, does/does not adequately demonstrate that the request is compliant with the Comprehensive Plan and Land Development Code to warrant approval at this time;

AND that BOA case number 2026-0002 does/does not meet the following criteria for granting a variance:

1. Special conditions do/do not exist that are peculiar to the land.
2. The granting the variance would not/would confer a special privilege to the applicant as the LDC allows for any property owner to apply for a variance.
3. A literal interpretation of the code would/would not deprive the applicant of the right to the reasonable use of their property, a right commonly enjoyed by others. Reasonable use of the property is limited in terms of privacy and safety.
4. The variance requested is/is not a minimum variance needed to make possible reasonable use of the land.
5. The granting of the variance would/would not be in harmony with the general intent of the Comprehensive Plan or the Land Development Code.

6. The variance would/would not be compatible with surrounding properties.

LIST OF EXHIBITS:

- EXHIBIT 1 BOA2026-0002 Variance Application**
 - EXHIBIT 2 Letter of Intent**
 - EXHIBIT 3 409 Stanley Drive Survey**
 - EXHIBIT 4 Topography and Tree Survey for 409 Stanley Dr**
 - EXHIBIT 5 Easterly 103 feet of Lot 5**
 - EXHIBIT 6 Westerly 100 feet of Lot 5**
 - EXHIBIT 7 Tree Health Assessment**
 - EXHIBIT 8 Nassau County Real Estate Annual Bill**
 - EXHIBIT 9 Forest Hills (1950) Subdivision**
 - EXHIBIT 10 Highland Dunes (2007) Subdivision**
-

Mackennah Tarmey

From: noreply@civicplus.com
Sent: Thursday, March 26, 2026 4:13 PM
To: Planning Info
Subject: Online Form Submittal: Board of Adjustment (BOA)

CAUTION: This email originated from outside the organization. Do not click links or open attachments unless you recognize the sender, were expecting this email, and know the content is safe.

Board of Adjustment (BOA)

BOARD OF ADJUSTMENT (BOA)

USE THIS FORM TO Apply for a variance to obtain relief from the design standards of this Land Development Code (LDC) where otherwise hardship would occur. A person who is adversely affected by any administrative decision may appeal such decision to the BOA.

Fees	Residential Properties \$1,500
------	--------------------------------

IMPORTANT NOTES

Application Requirements	A complete application filed at least forty-five (42) days before the date of the Board of Adjustment's public hearing;; A current signed, sealed, scaled survey of the property (no older than two years from date of application);, Proof of ownership (copy of deed or tax statement), A detailed letter stating the reasons for the request;; Materials as needed to illustrate the nature of the request, including but not limited to, site plans, architectural drawings, photographs, etc. (Site plans must be dimensioned and to scale).
--------------------------	---

Pre-Application Meeting

To guide you through the process and ensure that your application is understood and properly processed, you must meet with the applicable planner prior to submitting your application. Completed Board applications are **due forty-two (42) days prior** to the meeting date. Cases in the historic districts or Community Redevelopment Area are heard by the Historic District Council, please use the HDC Variance Application. Cases in all other areas of the City are heard by the Board of Adjustment.

Please see the Land Development Code	Procedures for Variances – LDC Section 10.02.04., Expiration of Variance Approval – LDC Section 10.02.04(C)., Appeals on
--------------------------------------	--

(LDC) for detailed information:

a Variance – LDC Section 10.02.04(D)., Appeals of Administrative Action – LDC 11.07.00

The LDC is available for review at

www.fbfl.us/LDC

Appeals

Any person aggrieved by any decision of the BOA regarding a variance may present to a court of record a petition, duly verified, setting forth that the decision is illegal, in whole or in part, specifying the grounds of the illegality. The petition shall be presented to the court within thirty (30) days after the filing of the decision at the office of the Board; otherwise, the decision of the Board shall be final.

Limitations on the Grant of a Variance

1. A variance shall not be granted which authorizes a use that is not permissible in the zoning district in which the property subject to the variance is located., 2. A variance shall not be granted which authorizes any use or standard that is prohibited by the City's Comprehensive Plan., 3. No nonconforming use of adjacent lands, structures, or buildings in the same zoning district, and no permitted use of land, structures, or buildings in other zoning districts, shall be considered g, 4. A variance shall not change the requirements for concurrency., 5. A variance shall not be granted to permit the use of a single media peonia for the construction of a dwelling unit., 6. A variance shall not be granted if the evidence submitted by an applicant is solely a demonstration of financial hardship or economic considerations., 7. A variance shall not be granted for procedure or process components of this Land Development Code., 8. A variance shall not be granted to deviate from LDC section 4.02.02 to combine two (2) or more lots which would result in a lot width greater than 100 feet for lots or parcels that abut Ocean Ave, 9. A variance will not be granted which authorizes the filling of wetlands prohibited by Land Development Code Section 3.03.03(A), 10. No variance shall be granted to exceed the maximum building height of 35 feet for a building on any lot within 800 feet of the mean highwater line of the Atlantic Ocean under LDC Section 4.02.03(D), 11. A variance shall not be granted for any residential or residential mixed-use structure to exceed the maximum building height requirements contained in Table 4.02.03(E)., 12. A variance shall not be granted to exceed the minimum side yard setbacks listed in Table 4.02.03(E) for any building within 800 feet of the mean high-water mark of the Atlantic Ocean.

REVIEW TYPE

Variance

Have you met with a planner for a pre-application meeting?

Yes

What was the date of your pre-application meeting? 3/16/2026

PROPERTY INFORMATION [Property information can be found at the Nassau County Property Appraiser's Website → Map Search](#)

Site Address 409 Stanley Drive

City FERNANDINA BEACH

State FL

Zip 32034

Parcel ID #(s) 00-00-31-128A-0005-0000

Zoning District R-1

Future Land Use Designation Low Density Residential

Do you authorize the installation of a temporary City notice sign on your property? YES

OWNER OF RECORD
As recorded with the Nassau County Property Appraiser

First Name Eric

Last Name Corbett

Company (if applicable) *Field not completed.*

Mailing Address 412 Escambia St

City FERNANDINA BEACH

State Florida

Zip 32034

Telephone Number 904-206-0052

E-mail Address 2674westthird@gmail.com

OWNER'S AGENT / APPLICANT

If other than owner. If an agent will be representing the owner, an Owner's Authorization For Agent Representation form must be included

First Name	Eric
Last Name	Corbett
Company (if applicable)	<i>Field not completed.</i>
Mailing Address	2674 WEST 3RD ST
City	FERNANDINA BEACH
State	FL
Zip	32034
Telephone Number	9042060052
E-mail Address	2674westthird@gmail.com

PROJECT INFORMATION

Variance Requested from LDC Section(s)	Divide a lot that is 100x203 into two lots - one 100x100 and one 100x103
Summary of Request (more detailed information to be provided in required letter of intent)	Requesting a variance on LDC 1.03.05

REQUIRED FINDINGS FOR A GRANT OF A VARIANCE

In order for an application for a variance to be approved or approved with conditions, the BOA must make a positive finding with regard to each of the provisions below. The applicant has the burden of proof of demonstrating that the application for a variance complies with each of the requirements. Please explain in detail how your case meets the following requirements:

1. Special Conditions: Special conditions and circumstances exist which are peculiar to the land, structure, or building involved and which are not applicable to other lands, structures, or	Shortly after purchasing the property, but prior to our application to demolish the existing home and pole barn, I met with the city planner and discussed my plans to demolish those structures and split the lot into two buildable lots – one for me to build on and the other for my brother to build on – and was given verbal permission to proceed. That verbal permission was then confirmed in an email exchange that followed the in-person meeting at the city hall offices. The lot that is currently 203 feet by 100 feet will be split to create one lot that is 103 feet by 100 feet that will face Stanley Drive (as the previous
---	---

buildings in the same zoning district. Special conditions or circumstances do not result from actions of the applicant and are not based on a desire to reduce development costs.

home did) and an additional lot of 100 feet by 100 feet that will face Highland Dunes Way. The special condition is the previous construction and current existence of the roadway "Highland Dunes Way" that was done 20-25 years ago, but long after the creation of the original Forest Hills subdivision plat in the 1950s. This roadway provides the access needed to create two lots where only one existed before.

2. Special Privilege: Granting the variance does not confer upon the applicant a special privilege that is denied by the Land Development Code to other lands, structures, or buildings in the same zoning district.

If there were a similar circumstance on a different lot I would think the variance would be provided there as well.

3. Literal Interpretation: Literal interpretation of the provisions of the Land Development Code would deprive the applicant of rights commonly enjoyed by other properties in the same zoning district.

The adjoining Highland Dunes subdivision has a minimum 75 foot lot width.

I should note that the Land Development Code 1.03.05 to me seems to be poorly written. The title of the Code reads "Construction or Demolition of Structures on Combined Lots". It is this code that I was told I am violating and therefore need to request a variance to obtain relief from. At my first reading of the code I simply thought that the code did not apply to me since I do not own a "combined lot" and the lot exists today the same way it has existed since it was originally platted – LOT 5 FOREST HILLS. But in the body of the code, it references creating a "lot of record" when "one or more lots" have been built on. This phrase "one or more lots" I think was intended to be written as "more than one lot". If it were written that way it would align perfectly with the title of the code that references "combined lots". Also the term "one or more lots" is duplicitous in that it would include ALL non-zero lot circumstances so if it really meant that, it would be unnecessary to say it at all as it would apply to all circumstances.

4. Minimum Variance: The variance requested is the minimum variance needed that will make possible the

The variance request is to split the single lot into only two lots. The two created lots will be 100 and 103 feet wide respectively and are still much wider than the minimum 75 feet required in R-1 zoning and the lot widths that currently exist throughout the adjoining Highland Dunes subdivision.

reasonable use of the land, structure, or building.	It should be noted that the two homes are expected to be smaller in footprint than the previous home and pole barn, creating less impervious area and minimal trees to be removed.
5. General Harmony: Granting the variance will be in harmony with the general intent and purpose of the Land Development Code and Comprehensive Plan.	Most lots in the previously existing Forest Hills subdivision are 100 feet wide and with varying depths that are up to 200 feet. Lots in the newer Highland Dunes subdivision are 75 feet wide with depths that vary from 75 feet to 110 feet. The two lots created will be approximately 100 feet by 100 feet creating a natural transition between the two subdivisions.
6. Public Interest: Granting the variance is compatible with surrounding properties, will not cause injury to the area involved, or otherwise be detrimental to the public health, safety, welfare or environment.	The proposed lots would be compatible with other properties along Stanley Drive and Highland Dunes Way that contain varying lot widths that are both greater than and lesser than the width of the proposed lots, therefore, the granting of the variance would not cause any injury to the area, or otherwise be detrimental to the public health, safety, welfare or environment.
Upload Supplemental Materials	Nassau-County-Real-Estate-00-00-31-128A-0005-0000-2025-Annual-bill.pdf
Upload 2	409 Stanley Dr Survey.pdf
Upload 3	Easterly 103 feet of Lot 5.pdf
Upload 4	westerly 100 feet of Lot 5.pdf
Upload 5	Tree Health Assessment Corbett c1.29.2026.pdf
Upload 6	Letter of Intent - 409 Stanley Dr.docx
Upload 7	topo-tree-boundary-survey-409 Stanley.pdf
Certification	By signing below, I certify that the information contained in this application is true and correct to the best of my knowledge at the time of the application., I acknowledge that I understand and have complied with all of the submittal requirements and procedures., I AGREE THAT A POSTING NOTICE WILL BE INSTALLED ON THE PROPERTY(IES) IN QUESTION AND THAT SAID SIGN WILL ONLY BE REMOVED BY STAFF AFTER THE MEETING OR BROUGHT BACK TO CITY HALL BY APPLICANT.

I/We understand that the City Staff will install a Notice of Hearing sign on the property 14 days before the scheduled hearing and that the sign must only be removed after the hearing by City Staff, unless, the applicant or property owner brings the Notice of Hearing back to City Hall.

Applicant's First Name Eric

Applicant's Last Name Corbett

Today's Date 3/26/2026

DEPARTMENT OF PLANNING & CONSERVATION
204 Ash Street | Fernandina Beach, Florida 32034 | 904 310-3480 |
www.fbfl.us/planning

Please make sure to disable pop-up blocker in order to submit.

Email not displaying correctly? [View it in your browser.](#)



City of Fernandina Beach
204 Ash Street
Fernandina Beach, FL 32034

RE: Letter of Intent – 409 Stanley Drive, Fernandina Beach, FL 32034

To Whom It May Concern:

I am requesting your review and approval for me to split my lot at 409 Stanley Drive into two lots. The lot is currently 100 feet by 203 feet and it is located at the corner of Stanley Drive and Highland Dunes Way. The lot currently faces Stanley Drive. I would like to split the lot into two lots that face Highland Dunes Way. The easterly lot will be 103 feet wide by 100 feet deep and the westerly lot will be 100 feet wide by 100 feet deep.

Thank you in advance for your consideration and I will await further direction from the City after you've reviewed my request.

Sincerely,

Eric T Corbett
412 Escambia St
Fernandina Beach, FL 32034
(904) 206 – 0052
2674westthird@gmail.com

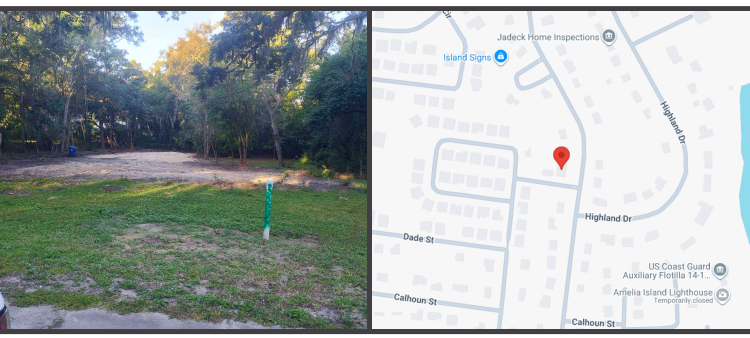

PROPERTY ADDRESS:
409 STANLEY DRIVE, FERNANDINA BEACH, FLORIDA 32034

SURVEY NUMBER: 2509.5794

CERTIFIED TO:
ERIC CORBETT

BUYER: Eric Corbett

LENDER:

TITLE COMPANY:

COMMITMENT DATE: NOT REVIEWED CLIENT FILE NO:

LEGAL DESCRIPTION:
LOT 5, FOREST HILLS SUBDIVISION SECTION ONE, ACCORDING TO THE PLAT THEREOF RECORDED IN PLAT BOOK 2, PAGE 76, OF THE PUBLIC RECORDS OF NASSAU COUNTY, FLORIDA.

JOB SPECIFIC SURVEYOR NOTES
THE BEARING REFERENCE OF SOUTH 7 DEGREES 32 MINUTES 00 SECONDS WEST IS BASED ON THE NORTHWESTERLY RIGHT-OF-WAY LINE OF STANLEY DRIVE, LOCATED WITHIN FOREST HILLS SUBDIVISION SECTION ONE ACCORDING TO THE PLAT THEREOF AS RECORDED IN PLAT BOOK 2, PAGE 76 OF THE PUBLIC RECORDS OF NASSAU COUNTY, FLORIDA.

DATE SIGNED: 10/23/25 FIELD WORK DATE: 10/21/2025

REVISION DATE(S):
(REVO 10/23/2025)

POINTS OF INTEREST
NONE VISIBLE

SURVEYORS CERTIFICATE
I hereby certify that this Survey of the lands described hereon was made under my direct supervision, and to the best of my knowledge and belief is a true and accurate representation of said lands and meets the Standards of Practice set forth in Chapter 5J-17.050 through 5J-17.053, Florida Administrative Code, pursuant to section 472.027, Florida Statutes. This survey is not valid without the signature and original raised seal of a Florida licensed surveyor and mapper, except when the electronic signature and seal of a Florida licensed surveyor and mapper is affixed hereto.



EXACTA
Exacta Land Surveyors, LLC
131 West Broward Street, Suite 300, Davie, FL 32703
Tel: 866.735.1916 | Fax: 866.744.2882

FLTA Florida Land Title Association **AFFILIATE MEMBERS**

ELEVATIONS SHOWN HEREON AS (x^o)
BASIS OF ELEVATIONS SHOWN
DESIGNATION: NAS 13
PID: BC2460
ELEVATION: 26.46
DATUM: NAVD 88

SURVEYOR'S NOTES:
FENCES EXIST, OWNERSHIP NOT DETERMINED.
DETBACK INFORMATION SHOWN ON PLAT, NOT VERIFIED.

LINE TABLE:
L1 S 7°32'00" W 50.00' (P)
S 7°21'53" W 49.71' (M)

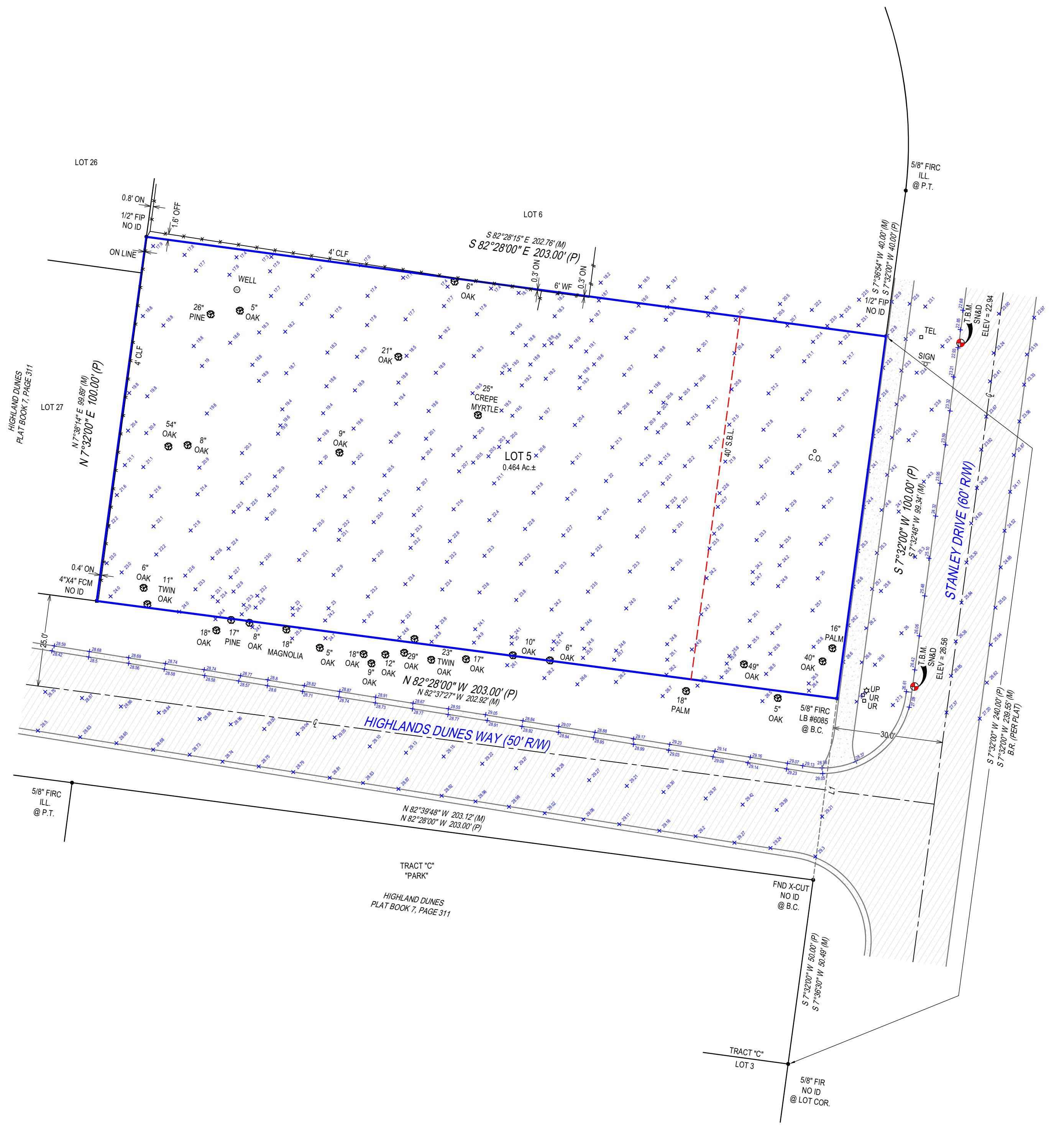

- GENERAL SURVEYORS NOTES:**
- The Legal Description used to perform this survey was supplied by others. This survey does not determine nor imply ownership of the lands or any fences shown hereon. Unless the Title Commitment Number and Date is referenced on this survey, an examination of the abstract of title was NOT performed by the signing surveyor to determine which instruments, if any, are affecting this property.
 - The purpose of this survey is to establish the boundary of the lands described by the legal description provided and to depict the visible improvements thereon for a pending financial transaction. Underground footings, utilities, or other service lines, including roof eave overhangs were not located as part of this survey. Unless specifically stated otherwise the purpose and intent of this survey is not for any construction activities or future planning.
 - If there is a septic tank or drain field shown on this survey, the location depicted hereon was either shown to the surveyor by a third party or it was estimated by visual above ground inspection. No excavation was performed to determine its location.
 - This survey is exclusively for a pending financial transaction and only to be used by the parties to whom it is certified.
 - Alterations to this survey map and report by other than the signing surveyor are prohibited.
 - Dimensions are in feet and decimals thereof.
 - Any FEMA flood zone data contained on this survey is for informational purposes only. Research to obtain said data was performed at www.fema.gov and may not reflect the most recent information.
 - Unless otherwise noted "SIRC" indicates a Set Iron Rebar with a Cap stamped LB#8291, a minimum half inch in diameter and eighteen inches long.
 - If you are reading this survey in an electronic format, the information contained on this document is only valid if this document is electronically signed as specified in Chapter 5J17.062 (3) of the Florida Administrative Code and Florida Statute 472.025. The Electronic Signature File related to this document is prominently displayed on the invoice for this survey which is sent under separate cover. Manually signed and sealed logs of all survey signature files are kept in the office of the performing surveyor.
 - The symbols reflected in the legend and on this survey may have been enlarged or reduced for clarity. The symbols have been plotted at the approximate center of the field location and may not represent the actual shape or size of the feature.
 - Points of Interest (POI's) are select above-ground improvements, which may appear in conflict with boundary, building setback or easement lines, as defined by the parameters of this survey. These POI's may not represent all items of interest to the viewer. There may be additional POI's which are not shown or called-out as POI's, or which are otherwise unknown to the surveyor.
 - Utilities shown on the subject property may or may not indicate the existence of recorded or unrecorded utility easements.
 - The information contained on this survey has been performed exclusively by and is the sole responsibility of Exacta Land Surveyors, LLC. Additional logos or references to third party firms are for informational purposes only.
 - Pursuant to F.S. 558.0035, an individual employee or agent may not be held individually liable for negligence.
 - Due to varying construction standards, building dimensions are approximate and are not intended to be used for new construction or planning.

SURVEYORS LEGEND:

LINETYPES	ABBREVIATIONS	MB - Map Book
Boundary Line	(C) - Calculated	ME - Maintenance Easement
Center Line	(D) - Deed	MES - Mitered End Section
Chain Link or Wire Fence	(F) - Field	MF - Metal Fence
Easement	(M) - Measured	MH - Manhole
Edge of Water	(P) - Plat	MHWL - Mean High Water Line
Iron Fence	(R) - Record	NR - Non-Radial
Overhead Lines	(S) - Survey	NTS - Not to Scale
Structure	A/C - Air Conditioning	NAVD88 - North American Vertical Datum 1988
Survey Tie Line	AE - Access Easement	NGVD29 - National Geodetic Vertical Datum 1929
Vinyl Fence	ANE - Anchor Easement	OG - On Ground
Wall or Party Wall	ASBL - Accessory Setback Line	ORB - Official Records Book
Wood Fence	B/W - Bay/Box Window	ORV - Official Record Volume
	BC - Block Corner	O/A - Overall
	BFP - Backflow Preventer	O/S - Offset
	BLDG - Building	OFF - Outside Subject Property
	BLK - Block	OH - Overhang
	BM - Benchmark	OHL - Overhead Utility Lines
	BR - Bearing Reference	OHWL - Ordinary High Water Line
	BRL - Building Restriction Line	ON - Inside Subject Property
	BSMT - Basement	P/E - Pool Equipment
	C - Curve	PB - Plat Book
Asphalt	CL - Center Line	PC - Point of Curvature
Brick or Tile	C/P - Covered Porch	PCC - Point of Compound Curvature
Concrete	C/S - Concrete Slab	PCP - Permanent Control Point
Covered Area	CATV - Cable TV Riser	PI - Point of Intersection
Water	CB - Concrete Block	PLS - Professional Land Surveyor
Wood	CH - Chord Bearing	PLT - Planter
	CHIM - Chimney	POB - Point of Beginning
	CLF - Chain Link Fence	POC - Point of Commencement
	CME - Canal Maintenance Easement	PRC - Point of Reverse Curvature
	CO - Clean Out	PRM - Permanent Reference Monument
	CONC - Concrete	PSM - Professional Surveyor & Mapper
	COR - Corner	PT - Point of Tangency
	CS/W - Concrete Sidewalk	PUE - Public Utility Easement
	CUE - Control Utility Easement	R - Radius or Radial
	CVG - Concrete Valley Gutter	R/W - Right of Way
	D/W - Driveway	RES - Residential
	DE - Drainage Easement	RE - Range
	DF - Drain Field	ROE - Roof Overhang Easement
	DH - Drill Hole	RP - Radius Point
	DUE - Drainage & Utility Easement	S/W - Sidewalk
	ELEV - Elevation	SCL - Survey Closure Line
	EM - Electric Meter	SCR - Screen
	ENCL - Enclosure	SEC - Section
	ENT - Entrance	SEP - Septic Tank
	EOP - Edge of Pavement	SEW - Sewer
	EOW - Edge of Water	SIRC - Set Iron Rod & Cap
	ESMT - Easement	SN&D - Set Nail and Disc
	EUB - Electric Utility Box	SQFT - Square Feet
	F/DH - Found Drill Hole	STL - Survey Tie Line
	FCM - Found Concrete Monument	STY - Story
	FF - Finished Floor	SV - Sewer Valve
	FIP - Found Iron Pipe	SWE - Sidewalk Easement
	FIPC - Found Iron Pipe & Cap	TBM - Temporary Bench Mark
	FIR - Found Iron Rod	TEL - Telephone Facilities
	FIRC - Found Iron Rod & Cap	TOB - Top of Bank
	FN - Found Nail	TUE - Technological Utility Easement
	FN&D - Found Nail & Disc	TWP - Township
	FR&SPK - Found Rail Road Spike	TX - Transformer
	GAR - Garage	TYP - Typical
	GM - Gas Meter	UE - Utility Easement
	ID - Identification	UG - Underground
	IE/EE - Ingress/Egress Easement	UP - Utility Riser
	ILL - Illegible	UR - Utility Riser
	INST - Instrument	VF - Vinyl Fence
	INT - Intersection	W/C - Witness Corner
	IRRE - Irrigation Easement	W/F - Water Filter
	L - Length	WF - Wood Fence
	LAE - Limited Access Easement	WM - Water Meter/Valve Box
	LB# - License No. (Business)	WV - Water valve
	LBE - Limited Buffer Easement	
	LE - Landscape Easement	
	LME - Lake/Landscape Maintenance Easement	
	LS# - License No. (Surveyor)	

FLOOD ZONE INFORMATION:
BY PERFORMING A SEARCH WITH THE LOCAL GOVERNING MUNICIPALITY OR WWW/FEMA.GOV, THE PROPERTY APPEARS TO BE LOCATED IN ZONE X. THIS PROPERTY WAS FOUND IN CITY OF FERNANDINA BEACH, COMMUNITY NUMBER 120172, PANEL NUMBER 0237 DATED 8/2/2017.

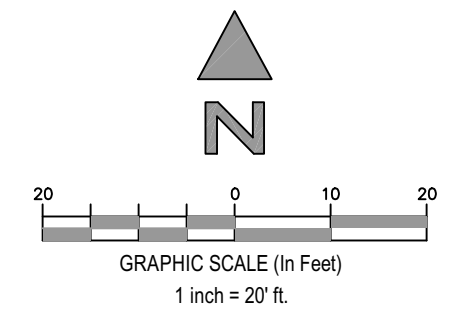

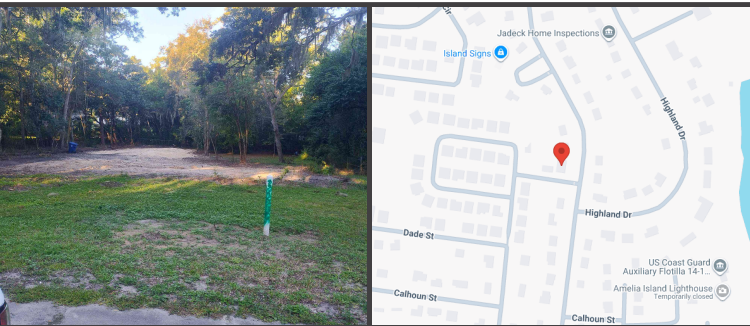

PROPERTY ADDRESS:
409 STANLEY DRIVE, FERNANDINA BEACH, FLORIDA 32034

SURVEY NUMBER: 2509.5794

CERTIFIED TO:
ERIC CORBETT

BUYER: Eric Corbett

LENDER:

TITLE COMPANY:

COMMITMENT DATE: NOT REVIEWED CLIENT FILE NO:

LEGAL DESCRIPTION:
LOT 5, FOREST HILLS SUBDIVISION SECTION ONE, ACCORDING TO THE PLAT THEREOF RECORDED IN PLAT BOOK 2, PAGE 76, OF THE PUBLIC RECORDS OF NASSAU COUNTY, FLORIDA.

JOB SPECIFIC SURVEYOR NOTES
THE BEARING REFERENCE OF SOUTH 7 DEGREES 32 MINUTES 00 SECONDS WEST IS BASED ON THE NORTHWESTERLY RIGHT-OF-WAY LINE OF STANLEY DRIVE, LOCATED WITHIN FOREST HILLS SUBDIVISION SECTION ONE ACCORDING TO THE PLAT THEREOF AS RECORDED IN PLAT BOOK 2, PAGE 76 OF THE PUBLIC RECORDS OF NASSAU COUNTY, FLORIDA.

DATE SIGNED: 10/23/25 FIELD WORK DATE: 10/21/2025

REVISION DATE(S):
(REVO 10/23/2025)

POINTS OF INTEREST
NONE VISIBLE

SURVEYORS CERTIFICATE
I hereby certify that this Survey of the lands described hereon was made under my direct supervision, and to the best of my knowledge and belief is a true and accurate representation of said lands and meets the Standards of Practice set forth in Chapter 5J-17.050 through 5J-17.053, Florida Administrative Code, pursuant to section 472.027, Florida Statutes. This survey is not valid without the signature and original raised seal of a Florida licensed surveyor and mapper, except when the electronic signature and seal of a Florida licensed surveyor and mapper is affixed hereto.

RAYMOND J. SCHAEFER
State of Florida Professional Surveyor and Mapper
License Number 6132
Exacta Land Surveyors, LLC | LB# 8291

EXACTA
Exacta Land Surveyors, LLC
Exacta Land Surveyors, LLC
131 West Broward Street, Suite 300, Ocala, FL 32703
P: 866.735.1916 | F: 866.744.2882

FLTA Florida Land Title Association **AFFILIATE MEMBERS**

ELEVATIONS SHOWN HEREON AS (x^o)

BASIS OF ELEVATIONS SHOWN
DESIGNATION: NAS 13
PID: BC2460
ELEVATION: 26.46
DATUM: NAVD 88

SURVEYOR'S NOTES:
FENCES EXIST, OWNERSHIP NOT DETERMINED.
DETBACK INFORMATION SHOWN ON PLAT, NOT VERIFIED.

LINE TABLE:
L1 S 7°32'00" W 50.00' (P)
S 7°21'53" W 49.71' (M)

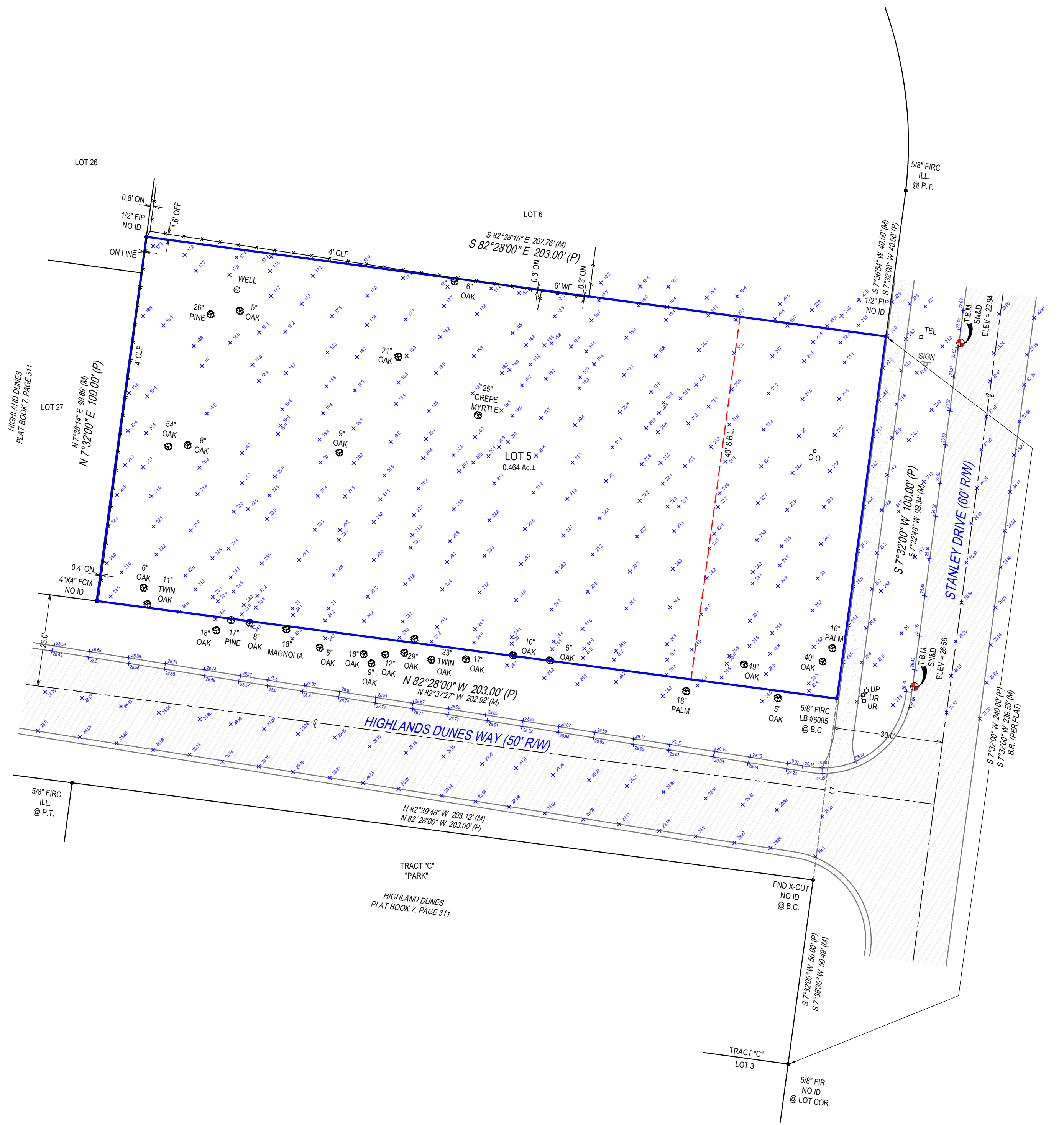

- GENERAL SURVEYORS NOTES:**
- The Legal Description used to perform this survey was supplied by others. This survey does not determine nor imply ownership of the lands or any fences shown hereon. Unless the Title Commitment Number and Date is referenced on this survey, an examination of the abstract of title was NOT performed by the signing surveyor to determine which instruments, if any, are affecting this property.
 - The purpose of this survey is to establish the boundary of the lands described by the legal description provided and to depict the visible improvements thereon for a pending financial transaction. Underground footings, utilities, or other service lines, including roof eave overhangs were not located as part of this survey. Unless specifically stated otherwise the purpose and intent of this survey is not for any construction activities or future planning.
 - If there is a septic tank or drain field shown on this survey, the location depicted hereon was either shown to the surveyor by a third party or it was estimated by visual above ground inspection. No excavation was performed to determine its location.
 - This survey is exclusively for a pending financial transaction and only to be used by the parties to whom it is certified.
 - Alterations to this survey map and report by other than the signing surveyor are prohibited.
 - Dimensions are in feet and decimals thereof.
 - Any FEMA flood zone data contained on this survey is for informational purposes only. Research to obtain said data was performed at www.fema.gov and may not reflect the most recent information.
 - Unless otherwise noted "SIRC" indicates a Set Iron Rebar with a Cap stamped LB#8291, a minimum half inch in diameter and eighteen inches long.
 - If you are reading this survey in an electronic format, the information contained on this document is only valid if this document is electronically signed as specified in Chapter 5J17.052 (3) of the Florida Administrative Code and Florida Statute 472.025. The Electronic Signature File related to this document is prominently displayed on the invoice for this survey which is sent under separate cover. Manually signed and sealed logs of all survey signature files are kept in the office of the performing surveyor.
 - The symbols reflected in the legend and on this survey may have been enlarged or reduced for clarity. The symbols have been plotted at the approximate center of the field location and may not represent the actual shape or size of the feature.
 - Points of Interest (POI's) are select above-ground improvements, which may appear in conflict with boundary, building setback or easement lines, as defined by the parameters of this survey. These POI's may not represent all items of interest to the viewer. There may be additional POI's which are not shown or called-out as POI's, or which are otherwise unknown to the surveyor.
 - Utilities shown on the subject property may or may not indicate the existence of recorded or unrecorded utility easements.
 - The information contained on this survey has been performed exclusively by and is the sole responsibility of Exacta Land Surveyors, LLC. Additional logos or references to third party firms are for informational purposes only.
 - Pursuant to F.S. 558.0035, an individual employee or agent may not be held individually liable for negligence.
 - Due to varying construction standards, building dimensions are approximate and are not intended to be used for new construction or planning.

SURVEYORS LEGEND:

LINETYPES	ABBREVIATIONS	MB - Map Book
Boundary Line	(C) - Calculated	ME - Maintenance Easement
Center Line	(D) - Deed	MES - Mitered End Section
Chain Link or Wire Fence	(F) - Field	MF - Metal Fence
Easement	(M) - Measured	MH - Manhole
Edge of Water	(P) - Plat	MHWL - Mean High Water Line
Iron Fence	(R) - Record	NR - Non-Radial
Overhead Lines	(S) - Survey	NTS - Not to Scale
Structure	A/C - Air Conditioning	NAVD88 - North American Vertical Datum 1988
Survey Tie Line	AE - Access Easement	NGVD29 - National Geodetic Vertical Datum 1929
Vinyl Fence	ANE - Anchor Easement	OG - On Ground
Wall or Party Wall	ASBL - Accessory Setback Line	ORB - Official Records Book
Wood Fence	B/W - Bay/Box Window	ORV - Official Record Volume
	BC - Block Corner	O/A - Overall
	BFP - Backflow Preventer	O/S - Offset
	BLDG - Building	OFF - Outside Subject Property
	BLK - Block	OH - Overhang
	BM - Benchmark	OHL - Overhead Utility Lines
	BR - Bearing Reference	OHWL - Ordinary High Water Line
	BRL - Building Restriction Line	ON - Inside Subject Property
	BSMT - Basement	P/E - Pool Equipment
	C - Curve	PB - Plat Book
Asphalt	CL - Center Line	PC - Point of Curvature
Brick or Tile	C/P - Covered Porch	PCC - Point of Compound Curvature
Concrete	C/S - Concrete Slab	PCP - Permanent Control Point
Covered Area	CATV - Cable TV Riser	PI - Point of Intersection
Water	CB - Concrete Block	PLS - Professional Land Surveyor
Wood	CH - Chord Bearing	PLT - Planter
	CHIM - Chimney	POB - Point of Beginning
	CLF - Chain Link Fence	POC - Point of Commencement
	CME - Canal Maintenance Easement	PRC - Point of Reverse Curvature
	CO - Clean Out	PRM - Permanent Reference Monument
	CONC - Concrete	PSM - Professional Surveyor & Mapper
	COR - Corner	PT - Point of Tangency
	CS/W - Concrete Sidewalk	PUE - Public Utility Easement
	CUE - Control Utility Easement	R - Radius or Radial
	CVG - Concrete Valley Gutter	R/W - Right of Way
	D/W - Driveway	RES - Residential
	DE - Drainage Easement	RE - Range
	DF - Drain Field	ROE - Roof Overhang Easement
	DH - Drill Hole	RP - Radius Point
	DUE - Drainage & Utility Easement	S/W - Sidewalk
	ELEV - Elevation	SCL - Survey Closure Line
	EM - Electric Meter	SCR - Screen
	ENCL - Enclosure	SEC - Section
	ENT - Entrance	SEP - Septic Tank
	EOP - Edge of Pavement	SEW - Sewer
	EOW - Edge of Water	SIRC - Set Iron Rod & Cap
	ESMT - Easement	SN&D - Set Nail and Disc
	EUB - Electric Utility Box	SQFT - Square Feet
	F/DH - Found Drill Hole	STL - Survey Tie Line
	FCM - Found Concrete Monument	STY - Story
	FF - Finished Floor	SV - Sewer Valve
	FIP - Found Iron Pipe	SWE - Sidewalk Easement
	FIPC - Found Iron Pipe & Cap	TBM - Temporary Bench Mark
	FIR - Found Iron Rod	TEL - Telephone Facilities
	FIRC - Found Iron Rod & Cap	TOB - Top of Bank
	FN - Found Nail	TUE - Technological Utility Easement
	FN&D - Found Nail & Disc	TWP - Township
	FR&SPK - Found Rail Road Spike	TX - Transformer
	GAR - Garage	TYP - Typical
	GM - Gas Meter	UE - Utility Easement
	ID - Identification	UG - Underground
	IE/EE - Ingress/Egress Easement	UP - Utility Riser
	ILL - Illegible	UR - Utility Riser
	INST - Instrument	VF - Vinyl Fence
	INT - Intersection	W/C - Witness Corner
	IRRE - Irrigation Easement	W/F - Water Filter
	L - Length	WM - Water Meter/Valve Box
	LAE - Limited Access Easement	WV - Water valve
	LB# - License No. (Business)	
	LBE - Limited Buffer Easement	
	LE - Landscape Easement	
	LME - Lake/Landscape Maintenance Easement	
	LS# - License No. (Surveyor)	

FLOOD ZONE INFORMATION:
BY PERFORMING A SEARCH WITH THE LOCAL GOVERNING MUNICIPALITY OR WWW/FEMA.GOV, THE PROPERTY APPEARS TO BE LOCATED IN ZONE X. THIS PROPERTY WAS FOUND IN CITY OF FERNANDINA BEACH, COMMUNITY NUMBER 120172, PANEL NUMBER 0237 DATED 8/2/2017.

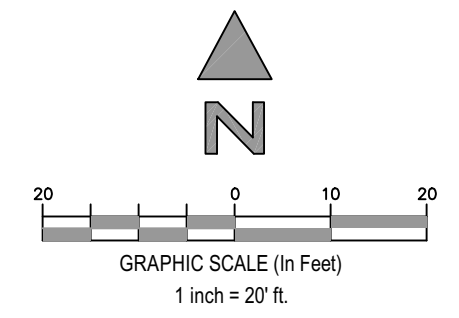

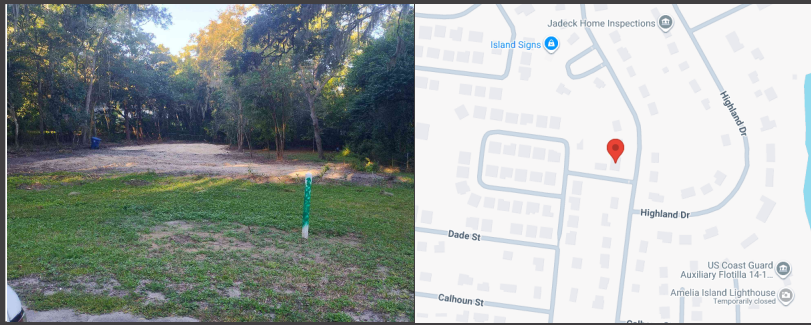

PROPERTY ADDRESS:
409 STANLEY DRIVE, FERNANDINA BEACH, FLORIDA 32034

SURVEY NUMBER: 2509.5794-02

DATE SIGNED: 10/29/25 **FIELD WORK DATE:** 10/21/2025

REVISION DATE(S):
(REV.1 11/4/2025) (REV.1 10/29/2025)

POINTS OF INTEREST
NONE VISIBLE

SURVEYORS CERTIFICATE

I hereby certify that this Survey of the lands described hereon was made under my direct supervision, and to the best of my knowledge and belief is a true and accurate representation of said lands and meets the Standards of Practice set forth in Chapter 5J-17.050 through 5J-17.053, Florida Administrative Code, pursuant to section 472.027, Florida Statutes. This survey is not valid without the signature and original raised seal of a Florida licensed surveyor and mapper, except when the electronic signature and seal of a Florida licensed surveyor and mapper is affixed hereto.



RAYMOND J. SCHAEFER
State of Florida Professional Surveyor and Mapper
License Number 6132
Exacta Land Surveyors, LLC | LB# 8291



Exacta Land Surveyors, LLC
LB# 8291
o: 866.735.1916 | f: 866.744.2882
131 West Broadway Street, Suite 1001, Oviedo, FL 32765



AFFILIATE MEMBERS

2509.5794-02
BOUNDARY SURVEY
NASSAU COUNTY

LINE TABLE:
L1 S 7°32'00" W 50.00' (D)
S 7°21'53" W 49.71' (M)

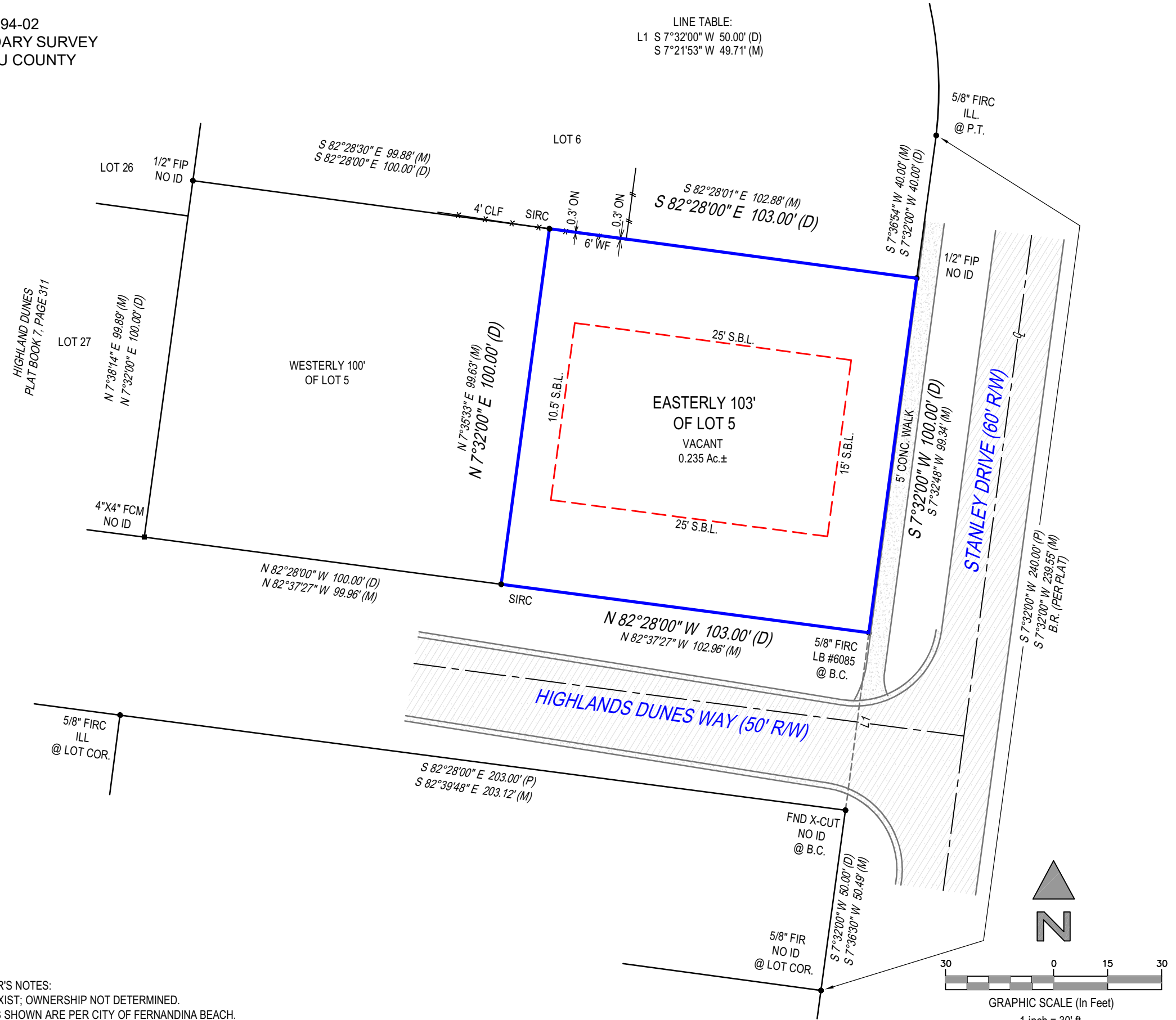

SURVEYOR'S NOTES:
FENCES EXIST; OWNERSHIP NOT DETERMINED.
SETBACKS SHOWN ARE PER CITY OF FERNANDINA BEACH.

SEE PAGE 2 OF 2 FOR LEGAL DESCRIPTION
PAGE 1 OF 2 - NOT VALID WITHOUT ALL PAGES

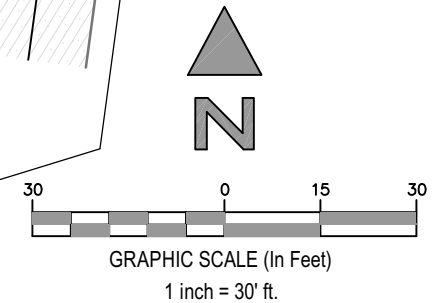

PROPERTY ADDRESS:
409 STANLEY DRIVE, FERNANDINA BEACH, FLORIDA 32034

SURVEY NUMBER: 2509.5794-02

CERTIFIED TO:
ERIC CORBETT

DATE SIGNED: 10/29/25

BUYER: Eric Corbett

LENDER:

TITLE COMPANY:

COMMITMENT DATE: NOT REVIEWED **CLIENT FILE NO:**

LEGAL DESCRIPTION:
LOT 5, EXCEPT THE WESTERLY 100.0 FEET THEREOF, FOREST HILLS SUBDIVISION SECTION ONE, ACCORDING TO THE PLAT THEREOF RECORDED IN PLAT BOOK 2, PAGE 76, OF THE PUBLIC RECORDS OF NASSAU COUNTY, FLORIDA.

FLOOD ZONE INFORMATION:

GENERAL SURVEYORS NOTES:

- The Legal Description used to perform this survey was supplied by others. This survey does not determine nor imply ownership of the lands or any fences shown hereon. Unless the Title Commitment Number and Date is referenced on this survey, an examination of the abstract of title was NOT performed by the signing surveyor to determine which instruments, if any, are affecting this property.
- The purpose of this survey is to establish the boundary of the lands described by the legal description provided and to depict the visible improvements thereon for a pending financial transaction. Underground footings, utilities, or other service lines, including roof eave overhangs were not located as part of this survey. Unless specifically stated otherwise the purpose and intent of this survey is not for any construction activities or future planning.
- If there is a septic tank or drain field shown on this survey, the location depicted hereon was either shown to the surveyor by a third party or it was estimated by visual above ground inspection. No excavation was performed to determine its location.
- This survey is exclusively for a pending financial transaction and only to be used by the parties to whom it is certified.
- Alterations to this survey map and report by other than the signing surveyor are prohibited.
- Dimensions are in feet and decimals thereof.
- Any FEMA flood zone data contained on this survey is for informational purposes only. Research to obtain said data was performed at www.fema.gov and may not reflect the most recent information.
- Unless otherwise noted "SIRC" indicates a Set Iron Rebar with a Cap stamped LB#8291, a minimum half inch in diameter and eighteen inches long.
- If you are reading this survey in an electronic format, the information contained on this document is only valid if this document is electronically signed as specified in Chapter 5J17.062 (3) of the Florida Administrative Code and Florida Statute 472.025. The Electronic Signature File related to this document is prominently displayed on the invoice for this survey which is sent under separate cover. Manually signed and sealed logs of all survey signature files are kept in the office of the performing surveyor.
- The symbols reflected in the legend and on this survey may have been enlarged or reduced for clarity. The symbols have been plotted at the approximate center of the field location and may not represent the actual shape or size of the feature.
- Points of Interest (POI's) are select above-ground improvements, which may appear in conflict with boundary, building setback or easement lines, as defined by the parameters of this survey. These POI's may not represent all items of interest to the viewer. There may be additional POI's which are not shown or called-out as POI's, or which are otherwise unknown to the surveyor.
- Utilities shown on the subject property may or may not indicate the existence of recorded or unrecorded utility easements.
- The information contained on this survey has been performed exclusively by and is the sole responsibility of Exacta Land Surveyors, LLC. Additional logos or references to third party firms are for informational purposes only.
- Pursuant to F.S. 558.0035, an individual employee or agent may not be held individually liable for negligence.
- Due to varying construction standards, building dimensions are approximate and are not intended to be used for new construction or planning.

SURVEYORS LEGEND:

LINETYPES		ABBREVIATIONS	
	Boundary Line	(C) - Calculated	FIP - Found Iron Pipe
	Center Line	(D) - Deed	FIPC - Found Iron Pipe & Cap
	Chain Link or Wire Fence	(F) - Field	FIR - Found Iron Rod
	Easement	(M) - Measured	FIRC - Found Iron Rod & Cap
	Edge of Water	(P) - Plat	FN - Found Nail
	Iron Fence	(R) - Record	FN&D - Found Nail & Disc
	Overhead Lines	(S) - Survey	FRRSPK - Found Rail Road Spike
	Structure	A/C - Air Conditioning	GAR - Garage
	Survey Tie Line	AE - Access Easement	GM - Gas Meter
	Vinyl Fence	ANE - Anchor Easement	ID - Identification
	Wall or Party Wall	ASBL - Accessory Setback Line	IE/EE - Ingress/Egress Easement
	Wood Fence	B/W - Bay/Box Window	ILL - Illegible
SURFACE TYPES		BC - Block Corner	INST - Instrument
	Asphalt	BFP - Backflow Preventer	INT - Intersection
	Brick or Tile	BLDG - Building	IRRE - Irrigation Easement
	Concrete	BLK - Block	L - Length
	Covered Area	BM - Benchmark	LAE - Limited Access Easement
	Water	BR - Bearing Reference	LB# - License No. (Business)
	Wood	BRL - Building Restriction Line	LBE - Limited Buffer Easement
SYMBOLS		BSMT - Basement	LE - Landscape Easement
	Benchmark	C - Curve	LME - Lake/Landscape Maintenance Easement
	Center Line	C/L - Center Line	LMS# - License No. (Surveyor)
	Central Angle or Delta	C/P - Covered Porch	MB - Map Book
	Common Ownership	C/S - Concrete Slab	ME - Maintenance Easement
	Control Point	CATV - Cable TV Riser	MES - Mitered End Section
	Catch Basin	CB - Concrete Block	MF - Metal Fence
	Elevation	CH - Chord Bearing	MH - Manhole
	Fire Hydrant	CHIM - Chimney	MHWL - Mean High Water Line
	Find or Set Monument	CLF - Chain Link Fence	NR - Non-Radial
	Guywire or Anchor	CME - Canal Maintenance Easement	NTS - Not to Scale
	Manhole	CO - Clean Out	NAVD88 - North American Vertical Datum 1988
	Tree	CONC - Concrete	NGVD29 - National Geodetic Vertical Datum 1929
	Utility or Light Pole	COR - Corner	OG - On Ground
	Well	CS/W - Concrete Sidewalk	ORB - Official Records Book
		CUE - Control Utility Easement	ORV - Official Record Volume
		CVG - Concrete Valley Gutter	O/A - Overall
		D/W - Driveway	O/S - Offset
		DE - Drainage Easement	OFF - Outside Subject Property
		DF - Drain Field	OH - Overhang
		DH - Drill Hole	OHL - Overhead Utility Lines
		DUE - Drainage & Utility Easement	OHWL - Ordinary High Water Line
		ELEV - Elevation	ON - Inside Subject Property
		EM - Electric Meter	P/E - Pool Equipment
		ENCL - Enclosure	PB - Plat Book
		ENT - Entrance	PC - Point of Curvature
		EOP - Edge of Pavement	PCC - Point of Compound Curvature
		EOW - Edge of Water	PCP - Permanent Control Point
		ESMT - Easement	PI - Point of Intersection
		EUB - Electric Utility Box	PLS - Professional Land
		F/DH - Found Drill Hole	
		FCM - Found Concrete Monument	
		FF - Finished Floor	

JOB SPECIFIC SURVEYOR NOTES:
REVISED 11/04/2025 TO ADJUST LOT SPLIT PER CLIENT REQUEST. THE BEARING REFERENCE OF SOUTH 7 DEGREES 32 MINUTES 00 SECONDS WEST IS BASED ON THE NORTHWESTERLY RIGHT-OF-WAY LINE OF STANLEY DRIVE, LOCATED WITHIN FOREST HILLS SUBDIVISION SECTION ONE ACCORDING TO THE PLAT THEREOF, AS RECORDED IN PLAT BOOK 2, PAGE 76 OF THE PUBLIC RECORDS OF NASSAU COUNTY, FLORIDA.



Exacta Land Surveyors, LLC
 Exacta Land Surveyors, LLC
 o: 866.735.1916 | f: 866.744.2882
 131 West Broadway Street, Suite 1001, Oviedo, FL 32765

SEE PAGE 1 OF 2 FOR MAP OF PROPERTY
PAGE 2 OF 2 - NOT VALID WITHOUT ALL PAGES

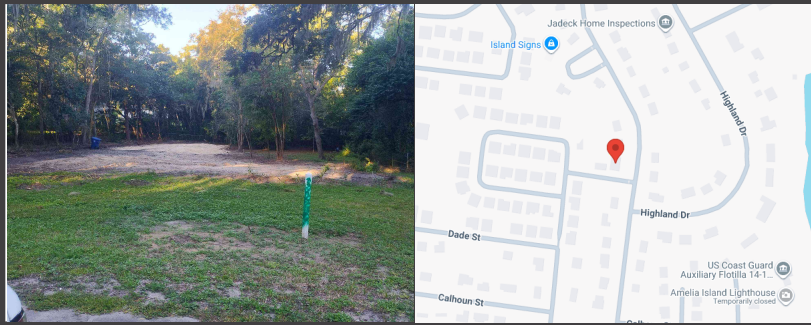

PROPERTY ADDRESS:
409 STANLEY DRIVE, FERNANDINA BEACH, FLORIDA 32034

SURVEY NUMBER: 2509.5794-01

DATE SIGNED: 10/29/25 **FIELD WORK DATE:** 10/21/2025

REVISION DATE(S):
(REV.1 11/4/2025) (REV.1 10/29/2025)

POINTS OF INTEREST
NONE VISIBLE

SURVEYORS CERTIFICATE

I hereby certify that this Survey of the lands described hereon was made under my direct supervision, and to the best of my knowledge and belief is a true and accurate representation of said lands and meets the Standards of Practice set forth in Chapter 5J-17.050 through 5J-17.053, Florida Administrative Code, pursuant to section 472.027, Florida Statutes. This survey is not valid without the signature and original raised seal of a Florida licensed surveyor and mapper, except when the electronic signature and seal of a Florida licensed surveyor and mapper is affixed hereto.



RAYMOND J. SCHAEFER
State of Florida Professional Surveyor and Mapper
License Number 6132
Exacta Land Surveyors, LLC | LB# 8291



Exacta Land Surveyors, LLC
LB# 8291
o: 866.735.1916 | f: 866.744.2882
131 West Broadway Street, Suite 1001, Oviedo, FL 32765



AFFILIATE MEMBERS

2509.5794-01
BOUNDARY SURVEY
NASSAU COUNTY

LINE TABLE:
L1 S 7°32'00" W 50.00' (D)
S 7°21'53" W 49.71' (M)

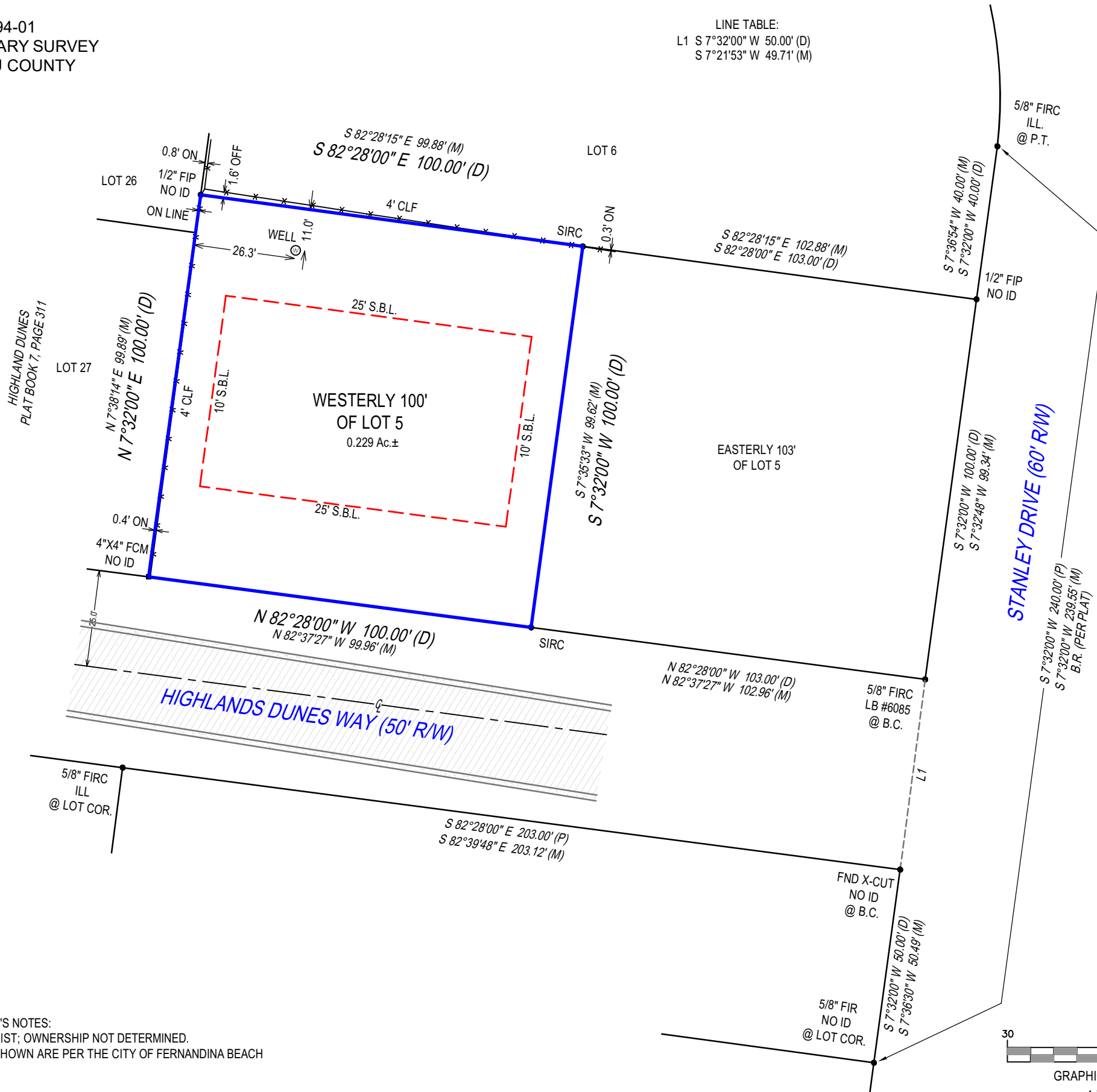

SURVEYOR'S NOTES:
FENCES EXIST; OWNERSHIP NOT DETERMINED.
SETBACKS SHOWN ARE PER THE CITY OF FERNANDINA BEACH

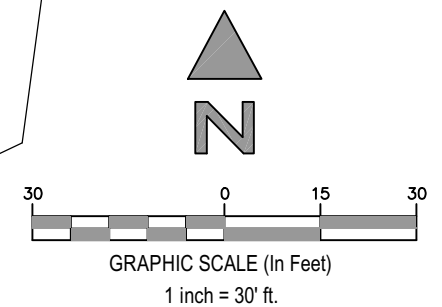

PROPERTY ADDRESS:
409 STANLEY DRIVE, FERNANDINA BEACH, FLORIDA 32034

SURVEY NUMBER: 2509.5794-01

CERTIFIED TO:
ERIC CORBETT

DATE SIGNED: 10/29/25

BUYER: Eric Corbett

LENDER:

TITLE COMPANY:

COMMITMENT DATE: NOT REVIEWED **CLIENT FILE NO:**

LEGAL DESCRIPTION:
THE WESTERLY 100.0 FEET OF LOT 5, FOREST HILLS SUBDIVISION SECTION ONE, ACCORDING TO THE PLAT THEREOF RECORDED IN PLAT BOOK 2, PAGE 76, OF THE PUBLIC RECORDS OF NASSAU COUNTY, FLORIDA.

FLOOD ZONE INFORMATION:
BY PERFORMING A SEARCH WITH THE LOCAL GOVERNING MUNICIPALITY OR WWW.FEMA.GOV, THE PROPERTY APPEARS TO BE LOCATED IN ZONE X. THIS PROPERTY WAS FOUND IN CITY OF FERNANDINA BEACH, COMMUNITY NUMBER 120172, PANEL NUMBER 0237 DATED 8/2/2017.

- GENERAL SURVEYORS NOTES:**
- The Legal Description used to perform this survey was supplied by others. This survey does not determine nor imply ownership of the lands or any fences shown hereon. Unless the Title Commitment Number and Date is referenced on this survey, an examination of the abstract of title was NOT performed by the signing surveyor to determine which instruments, if any, are affecting this property.
 - The purpose of this survey is to establish the boundary of the lands described by the legal description provided and to depict the visible improvements thereon for a pending financial transaction. Underground footings, utilities, or other service lines, including roof eave overhangs were not located as part of this survey. Unless specifically stated otherwise the purpose and intent of this survey is not for any construction activities or future planning.
 - If there is a septic tank or drain field shown on this survey, the location depicted hereon was either shown to the surveyor by a third party or it was estimated by visual above ground inspection. No excavation was performed to determine its location.
 - This survey is exclusively for a pending financial transaction and only to be used by the parties to whom it is certified.
 - Alterations to this survey map and report by other than the signing surveyor are prohibited.
 - Dimensions are in feet and decimals thereof.
 - Any FEMA flood zone data contained on this survey is for informational purposes only. Research to obtain said data was performed at www.fema.gov and may not reflect the most recent information.
 - Unless otherwise noted "SIRC" indicates a Set Iron Rebar with a Cap stamped LB#8291, a minimum half inch in diameter and eighteen inches long.
 - If you are reading this survey in an electronic format, the information contained on this document is only valid if this document is electronically signed as specified in Chapter 5J17.062 (3) of the Florida Administrative Code and Florida Statute 472.025. The Electronic Signature File related to this document is prominently displayed on the invoice for this survey which is sent under separate cover. Manually signed and sealed logs of all survey signature files are kept in the office of the performing surveyor.
 - The symbols reflected in the legend and on this survey may have been enlarged or reduced for clarity. The symbols have been plotted at the approximate center of the field location and may not represent the actual shape or size of the feature.
 - Points of Interest (POI's) are select above-ground improvements, which may appear in conflict with boundary, building setback or easement lines, as defined by the parameters of this survey. These POI's may not represent all items of interest to the viewer. There may be additional POI's which are not shown or called-out as POI's, or which are otherwise unknown to the surveyor.
 - Utilities shown on the subject property may or may not indicate the existence of recorded or unrecorded utility easements.
 - The information contained on this survey has been performed exclusively by and is the sole responsibility of Exacta Land Surveyors, LLC. Additional logos or references to third party firms are for informational purposes only.
 - Pursuant to F.S. 558.0035, an individual employee or agent may not be held individually liable for negligence.
 - Due to varying construction standards, building dimensions are approximate and are not intended to be used for new construction or planning.

SURVEYORS LEGEND:

LINETYPES	
	Boundary Line
	Center Line
	Chain Link or Wire Fence
	Easement
	Edge of Water
	Iron Fence
	Overhead Lines
	Structure
	Survey Tie Line
	Vinyl Fence
	Wall or Party Wall
	Wood Fence
SURFACE TYPES	
	Asphalt
	Brick or Tile
	Concrete
	Covered Area
	Water
	Wood
SYMBOLS	
	Benchmark
	Center Line
	Central Angle or Delta
	Common Ownership
	Control Point
	Catch Basin
	Elevation
	Fire Hydrant
	Find or Set Monument
	Guywire or Anchor
	Manhole
	Tree
	Utility or Light Pole
	Well

<p>ABBREVIATIONS</p> <p>(C) - Calculated (D) - Deed (F) - Field (M) - Measured (P) - Plat (R) - Record (S) - Survey A/C - Air Conditioning AE - Access Easement ANE - Anchor Easement ASBL - Accessory Setback Line B/W - Bay/Box Window BC - Block Corner BFP - Backflow Preventer BLDG - Building BLK - Block BM - Benchmark BR - Bearing Reference BRL - Building Restriction Line BSMT - Basement C - Curve C/L - Center Line C/P - Covered Porch C/S - Concrete Slab CATV - Cable TV Riser CB - Concrete Block CH - Chord Bearing CHIM - Chimney CLF - Chain Link Fence CME - Canal Maintenance Easement CO - Clean Out CONC - Concrete COR - Corner CS/W - Concrete Sidewalk CUE - Control Utility Easement CVG - Concrete Valley Gutter D/W - Driveway DE - Drainage Easement DF - Drain Field DH - Drill Hole DUE - Drainage & Utility Easement ELEV - Elevation EM - Electric Meter ENCL - Enclosure ENT - Entrance EOP - Edge of Pavement EOW - Edge of Water ESMT - Easement EUB - Electric Utility Box F/DH - Found Drill Hole FCM - Found Concrete Monument FF - Finished Floor</p>	<p>FIP - Found Iron Pipe FIPC - Found Iron Pipe & Cap FIR - Found Iron Rod FIRC - Found Iron Rod & Cap FN - Found Nail FN&D - Found Nail & Disc FRRSPK - Found Rail Road Spike GAR - Garage GM - Gas Meter ID - Identification IE/EE - Ingress/Egress Easement ILL - Illegible INST - Instrument INT - Intersection IRRE - Irrigation Easement L - Length LAE - Limited Access Easement LB# - License No. (Business) LBE - Limited Buffer Easement LE - Landscape Easement LME - Lake/Landscape Maintenance Easement LS# - License No. (Surveyor) MB - Map Book ME - Maintenance Easement MES - Mitered End Section MF - Metal Fence MH - Manhole MHWL - Mean High Water Line NR - Non-Radial NTS - Not to Scale NAVD88 - North American Vertical Datum 1988 NGVD29 - National Geodetic Vertical Datum 1929 OG - On Ground ORB - Official Records Book ORV - Official Record Volume O/A - Overall O/S - Offset OFF - Outside Subject Property OH - Overhang OHL - Overhead Utility Lines OHWL - Ordinary High Water Line ON - Inside Subject Property P/E - Pool Equipment PB - Plat Book PC - Point of Curvature PCC - Point of Compound Curvature PCP - Permanent Control Point PI - Point of Intersection PLS - Professional Land</p>	<p>Surveyor PLT - Planter POB - Point of Beginning POC - Point of Commencement PRC - Point of Reverse Curvature PRM - Permanent Reference Monument PSM - Professional Surveyor & Mapper PT - Point of Tangency PUE - Public Utility Easement R - Radius or Radial R/W - Right of Way RES - Residential RGE - Range ROE - Roof Overhang Easement RP - Radius Point S/W - Sidewalk SBL - Setback Line SCL - Survey Closure Line SCR - Screen SEC - Section SEP - Septic Tank SEW - Sewer SIRC - Set Iron Rod & Cap SMWE - Storm Water Management Easement SN&D - Set Nail and Disc SQFT - Square Feet STL - Survey Tie Line STY - Story SV - Sewer Valve SWE - Sidewalk Easement TBM - Temporary Bench Mark TEL - Telephone Facilities TOB - Top of Bank TUE - Technological Utility Easement TWP - Township TX - Transformer TYP - Typical UE - Utility Easement UG - Underground UP - Utility Pole UR - Utility Riser VF - Vinyl Fence W/C - Witness Corner W/F - Water Filter WF - Wood Fence WM - Water Meter/Valve Box WV - Water valve</p>
---	---	--

JOB SPECIFIC SURVEYOR NOTES:
REVISED 11/04/2025 TO ADJUST LOT SPLIT PER CLIENT REQUEST.

THE BEARING REFERENCE OF SOUTH 7 DEGREES 32 MINUTES 00 SECONDS WEST IS BASED ON THE NORTHWESTERLY RIGHT-OF-WAY LINE OF STANLEY DRIVE, LOCATED WITHIN FOREST HILLS SUBDIVISION SECTION ONE ACCORDING TO THE PLAT THEREOF, AS RECORDED IN PLAT BOOK 2, PAGE 76 OF THE PUBLIC RECORDS OF NASSAU COUNTY, FLORIDA.



Exacta Land Surveyors, LLC
Exacta Land Surveyors, LLC
 o: 866.735.1916 | f: 866.744.2882
 131 West Broadway Street, Suite 1001, Oviedo, FL 32765

SEE PAGE 1 OF 2 FOR MAP OF PROPERTY
PAGE 2 OF 2 - NOT VALID WITHOUT ALL PAGES

Eric Corbett - 409 Stanley Dr.

Tree Health Assessment

TRNO	Descrip	Dbh	Species	Status	Comment
1	18" Palm	18	Sabal	1	
2	40" Oak	40	LO	1	
3	49" Oak	49	LO	3	minor damage @ 8 feet - leans away from #2 and toward lot
4	5" Oak	5	Holly	3	Out of Bounds - multiple top and leans toward Highland Dunes.
5	18" Palm	18	Sabal	1	Out of Bounds
6	6" Oak	6	Ligus	4	Not a tree - Ligustrum - has splits and a poor top
7	10" Oak	10	LAU	1	
8	17" Oak	17	LAU	3	Out of Bounds - decline in the tree and a dead top.
9	23" Twin Oak	23	LAU	3	Out of Bounds - forked at 2 feet
10	13"Oak	13	LAU	3	leans from competition behind it and toward where house will be.
11	29" Oak	29	LAU	4	Out of Bounds - forked at 6 feet with a poor codominant connection.
12	12" Oak	12	LAU	3	Out of Bounds - bowed over toward the Highland Dunes Way.
13	9" Oak	9	LAU	3	Out of Bounds - bowed over toward the Highland Dunes Way.
14	18" Oak	18	LAU	1	Out of Bounds
15	5" Oak	5	LAU	2	Out of Bounds - understory tree - shaded and leans
16	18" Mag	18	MAG	1	Out of Bounds
17	8" Oak	8	CAM	4	invasive species and poor tree
18	17" Pine	17	SL	3	mechanical damage at the base - tree is on the line
19	18" Oak	18	LAU	2	Out of Bounds - forked at 6 feet and leans slightly
20	11" Twin Oak	11	CAM	3	invasive species
21	6" Oak	6	LAU	2	small and crooked
22	8" Oak	8	Orn	4	Splits in the side and dead wood. Very near #23.
23	54" Oak	54	LO	2	some dead wood and a fork with two large sections at 7 feet.
24	26" Pine	26	SL	1	
25	5" Oak	8	Ligus	1	
26	9" Oak	9	Orn	3	some sort of fruit tree - dead wood and some decay.
27	21" Oak	21	PCN	2	leans slightly in the direction of where the house pad will be.
28	25" Crepe	25	Crepe	1	
29	6" Oak	6	Ligus	3	not a tree - Ligustrum - on the fence and leans toward the lot.

Status definition

1= no apparent defect

2= slight defect

3= defective but can keep

4= severe defect - recommend removal

5= hazardous defect or dead - remove

Early Y. McCall

ISA Certified Arborist FL6200A

McCall Tree Health and Consulting LLC

Eric Corbett - 409 Stanley Dr.

Tree Health Assessment

Species Key

Code	Species	trees	
LO	Live Oak	3	
LAU	Laurel Oak	11	
SL	Slash Pine	2	
Sabal	Sabal palmetto	2	
Mag	Magnolia	1	
Crepe	Crepe Myrtle	1	
Holly	Holly	1	
ORN	Ornamental	2	
PCN	Pecan	1	
Ligus	Ligustrum shrub	3	not considered a tree
CAM	Camphor	2	invasive

29

